

## FEATURES

- ▶ SMD Package with Industry Standard Pinout
- ▶ Package Dimension:  
15.3 x 8.0 x 7.1 mm (0.6"x 0.31"x 0.28")
- ▶ High I/O-Isolation 3000 VDC
- ▶ Operating Temp. Range -40° to +85°C
- ▶ High Accuracy of Pin Planarity
- ▶ Qualified for lead-free reflow solder process according  
IPC/JEDEC J-STD-020D
- ▶ Tape & Reel Package available
- ▶ 3 Year Product Warranty



## PRODUCT OVERVIEW

The MINMAX MSAU300 series is a range of 1W DC/DC converters in a SMD- Package featuring high I/O-isolation of 3000VDC. The small footprint makes this product the ideal solution for many applications where a voltage has to be isolated i.e. for noise reduction, ground loop elimination, in digital interfaces or where a higher I/O isolation is required.

An excellent efficiency allows an operating temperature range of -40°C to +85°C. These converters are fully qualified for the higher temperature profile used in lead-free reflow solder processes. For automated SMD production lines the product can also be supplied in tape & reel package.

### Model Selection Guide

| Model Number | Input Voltage (Range)<br>VDC | Output Voltage<br>VDC | Output Current |            | Input Current          |                      | Load Regulation<br>% (max.) | Max. capacitive Load<br>uF | Efficiency (typ.)<br>@Max. Load<br>% |
|--------------|------------------------------|-----------------------|----------------|------------|------------------------|----------------------|-----------------------------|----------------------------|--------------------------------------|
|              |                              |                       | Max.<br>mA     | Min.<br>mA | @Max. Load<br>mA(typ.) | @No Load<br>mA(typ.) |                             |                            |                                      |
| MSAU301      | 5<br>(4.5 ~ 5.5)             | 5                     | 200            | 4          | 281                    | 30                   | 10                          | 33                         | 71                                   |
| MSAU303      |                              | 12                    | 84             | 1.5        | 258                    |                      | 7                           | 4.7                        | 78                                   |
| MSAU304      |                              | 15                    | 67             | 1          | 258                    |                      | 7                           | 4.7                        | 78                                   |
| MSAU306      |                              | ±5                    | ±100           | ±2         | 277                    |                      | 10                          | 10#                        | 72                                   |
| MSAU308      |                              | ±12                   | ±42            | ±0.8       | 255                    |                      | 7                           | 2.2#                       | 78                                   |
| MSAU309      |                              | ±15                   | ±34            | ±0.7       | 258                    |                      | 7                           | 2.2#                       | 79                                   |
| MSAU311      | 12<br>(10.8 ~ 13.2)          | 5                     | 200            | 4          | 117                    | 12                   | 8                           | 33                         | 71                                   |
| MSAU313      |                              | 12                    | 84             | 1.5        | 106                    |                      | 5                           | 4.7                        | 79                                   |
| MSAU314      |                              | 15                    | 67             | 1          | 104                    |                      | 5                           | 4.7                        | 80                                   |
| MSAU316      |                              | ±5                    | ±100           | ±2         | 112                    |                      | 8                           | 10#                        | 74                                   |
| MSAU318      |                              | ±12                   | ±42            | ±0.8       | 105                    |                      | 5                           | 2.2#                       | 80                                   |
| MSAU319      |                              | ±15                   | ±34            | ±0.7       | 104                    |                      | 5                           | 2.2#                       | 81                                   |
| MSAU321      | 24<br>(21.6 ~ 26.4)          | 5                     | 200            | 4          | 58                     | 7                    | 8                           | 33                         | 71                                   |
| MSAU323      |                              | 12                    | 84             | 1.5        | 53                     |                      | 5                           | 4.7                        | 78                                   |
| MSAU324      |                              | 15                    | 67             | 1          | 53                     |                      | 5                           | 4.7                        | 79                                   |
| MSAU326      |                              | ±5                    | ±100           | ±2         | 57                     |                      | 8                           | 10#                        | 72                                   |
| MSAU328      |                              | ±12                   | ±42            | ±0.8       | 53                     |                      | 5                           | 2.2#                       | 79                                   |
| MSAU329      |                              | ±15                   | ±34            | ±0.7       | 53                     |                      | 5                           | 2.2#                       | 80                                   |

# For each output

### Input Specifications

| Parameter                         | Model            | Min.               | Typ. | Max. | Unit |
|-----------------------------------|------------------|--------------------|------|------|------|
| Input Voltage Range               | 5V Input Models  | 4.5                | 5    | 5.5  | VDC  |
|                                   | 12V Input Models | 10.8               | 12   | 13.2 |      |
|                                   | 24V Input Models | 21.6               | 24   | 26.4 |      |
| Input Surge Voltage (1 sec. max.) | 5V Input Models  | -0.7               | ---  | 9    | VDC  |
|                                   | 12V Input Models | -0.7               | ---  | 18   |      |
|                                   | 24V Input Models | -0.7               | ---  | 30   |      |
| Reverse Polarity Input Current    | All Models       | ---                | ---  | 0.3  | A    |
| Input Filter                      |                  | Internal Capacitor |      |      |      |
| Internal Power Dissipation        |                  | ---                | ---  | 550  | mW   |

**Output Specifications**

| Parameter                | Conditions                  | Min. | Typ.                      | Max.  | Unit              |
|--------------------------|-----------------------------|------|---------------------------|-------|-------------------|
| Output Voltage Accuracy  |                             | ---  | ±1.5                      | ±4.0  | %                 |
| Output Voltage Balance   | Dual Output, Balanced Loads | ---  | ±0.1                      | ±1.0  | %                 |
| Line Regulation          | For Vin Change of 1%        | ---  | ±1.2                      | ±1.5  | %                 |
| Load Regulation          | Io=20% to 100%              |      | See Model Selection Guide |       |                   |
| Ripple & Noise (20MHz)   |                             | ---  | 75                        | 100   | mV <sub>P-P</sub> |
| Ripple & Noise (20MHz)   | Over Line, Load & Temp.     | ---  | ---                       | 150   | mV <sub>P-P</sub> |
| Ripple & Noise (20MHz)   |                             | ---  | ---                       | 15    | mV rms            |
| Temperature Coefficient  |                             | ---  | ±0.01                     | ±0.02 | %/°C              |
| Short Circuit Protection |                             |      | 0.5 Second Max.           |       |                   |

**General Specifications**

| Parameter                        | Conditions                        | Min.      | Typ.    | Max.  | Unit  |
|----------------------------------|-----------------------------------|-----------|---------|-------|-------|
| I/O Isolation Voltage (rated)    | 60 Seconds                        | 3000      | ---     | ---   | VDC   |
| I/O Isolation Resistance         | 500 VDC                           | 10        | ---     | ---   | GΩ    |
| I/O Isolation Capacitance        | 100KHz, 1V                        | ---       | 60      | 100   | pF    |
| Switching Frequency              |                                   | 50        | 100     | 150   | KHz   |
| MTBF (calculated)                | MIL-HDBK-217F@25°C, Ground Benign | 2,000,000 | -----   | ----- | Hours |
| Moisture Sensitivity Level (MSL) | IPC/JEDEC J-STD-020D              |           | Level 3 |       |       |

**Input Fuse**

| 5V Input Models      | 12V Input Models     | 24V Input Models     |
|----------------------|----------------------|----------------------|
| 500mA Slow-Blow Type | 200mA Slow-Blow Type | 100mA Slow-Blow Type |

**Environmental Specifications**

| Parameter                                     | Conditions          | Min. | Max. | Unit     |
|---|---------------------|------|------|----------|
| Operating Temperature Range (with Derating)   | Ambient             | -40  | +85  | °C       |
| Case Temperature                              |                     | ---  | +90  | °C       |
| Storage Temperature Range                     |                     | -50  | +125 | °C       |
| Humidity (non condensing)                     |                     | ---  | 95   | % rel. H |
| Cooling                                       | Free-Air convection |      |      |          |
| Lead Temperature (1.5mm from case for 10Sec.) |                     | ---  | 300  | °C       |

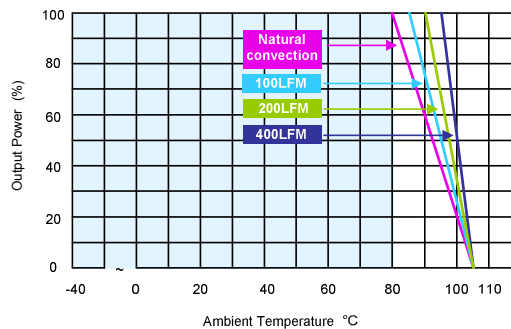
**Power Derating Curve**

**Notes**

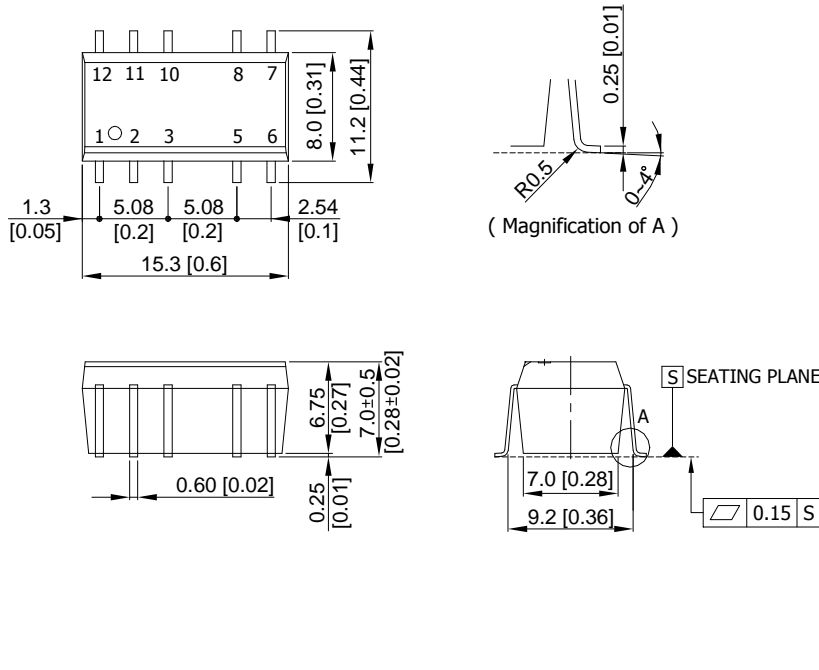
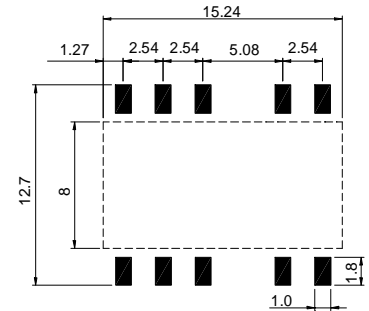
- Specifications typical at Ta=+25°C, resistive load, nominal input voltage and rated output current unless otherwise noted.
- Ripple & Noise measurement bandwidth is 0-20MHz.
- These power converters require a minimum output loading to maintain specified regulation, operation under no-load conditions will not damage these modules; however they may not meet all specifications listed.
- All DC/DC converters should be externally fused at the front end for protection.
- Other input and output voltage may be available, please contact factory.
- Specifications subject to change without notice.

**Package Specifications**
**Mechanical Dimensions**

**Connecting Pin Patterns**

- ▶ All dimensions in mm (inches)
- ▶ Tolerance: X.X±0.25 (X.XX±0.01)  
X.XX±0.13 ( X.XXX±0.005)
- ▶ Pin pitch tolerance: ±0.25 (0.01)

**Pin Connections**

| Pin | Single Output | Dual Output |
|-----|---------------|-------------|
| 1   | -Vin          | -Vin        |
| 2   | +Vin          | +Vin        |
| 3   | NA            | NA          |
| 5   | -Vout         | Common      |
| 6   | NA            | -Vout       |
| 7   | NA            | NA          |
| 8   | +Vout         | +Vout       |
| 10  | NA            | NA          |
| 11  | NA            | NA          |
| 12  | NA            | NA          |

NA : Not Available for Electrical Connection

**Physical Characteristics**

|               |  |
|---------------|--|
| Case Size     | : 15.3x8.0x6.75mm (0.60x0.31x0.27 Inches)  |
| Case Material | : Molding (flammability to UL 94V-0 rated) |
| Weight        | : 2.2g                                     |

## Test Configurations

### Input Reflected-Ripple Current Test Setup

Input reflected-ripple current is measured with an inductor  $L_{in}$  (4.7uH) and  $C_{in}$  (220uF, ESR < 1.0Ω at 100 KHz) to simulate source impedance. Capacitor  $C_{in}$ , offsets possible battery impedance.

Current ripple is measured at the input terminals of the module, measurement bandwidth is 0-500 KHz.

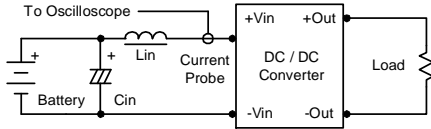

### Peak-to-Peak Output Noise Measurement Test

Use a  $C_{out}$  0.33uF ceramic capacitor. Scope measurement should be made by using a BNC socket, measurement bandwidth is 0-20 MHz. Position the load between 50 mm and 75 mm from the DC/DC Converter.

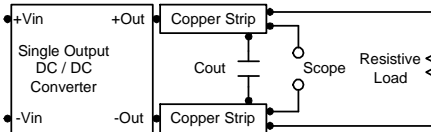

## Design & Feature Considerations

### Maximum Capacitive Load

The MSAU300 series has limitation of maximum connected capacitance at the output. The power module may be operated in current limiting mode during start-up, affecting the ramp-up and the startup time. The maximum capacitance can be found in the data sheet.

### Input Source Impedance

The power module should be connected to a low ac-impedance input source. Highly inductive source impedances can affect the stability of the power module. In applications where power is supplied over long lines and output loading is high, it may be necessary to use a capacitor at the input to ensure startup.

Capacitor mounted close to the power module helps ensure stability of the unit, it is recommended to use a good quality low Equivalent Series Resistance (ESR < 1.0Ω at 100 KHz) capacitor of a 2.2uF for the 5V input devices, a 1.0uF for the 12V input devices and a 0.47uF for the 24V devices..

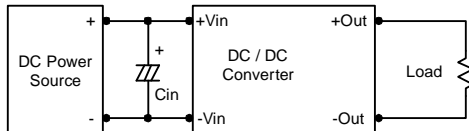

### Output Ripple Reduction

A good quality low ESR capacitor placed as close as practicable across the load will give the best ripple and noise performance. To reduce output ripple, it is recommended to use 1.0uF capacitors at the output.

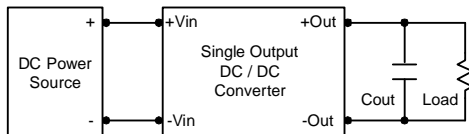

### Thermal Considerations

Many conditions affect the thermal performance of the power module, such as orientation, airflow over the module and board spacing. To avoid exceeding the maximum temperature rating of the components inside the power module, the case temperature must be kept below 90°C. The derating curves are determined from measurements obtained in a test setup.

