

NEW
FEATURES

- ▶ Fully Encapsulated Plastic Case for Chassis and DIN-Rail Mounting Version
- ▶ Ultra-wide 4:1 Input Voltage Range
- ▶ Fully Regulated Output Voltage
- ▶ High Efficiency up to 86%
- ▶ I/O Isolation 3000 VDC
- ▶ Operating Ambient Temp. Range -40°C to +92.5°C
- ▶ No Min. Load Requirement
- ▶ Under-voltage, Overload and Short Circuit Protection
- ▶ Remote On/Off Control
- ▶ EMI Emission EN 55032 Class A & FCC Level A Approved (Pending)
- ▶ EMC Immunity EN 61000-4-2,3,4,5,6,8 Approved (Pending)
- ▶ UL/cUL/IEC/EN 62368-1 Safety Approval & CE Marking



 UL 62368-1



PRODUCT OVERVIEW

The MINMAX MKW110C series is a new range of high performance DC-DC converters featuring a wide 4:1 input range in a chassis-mount package with terminal strip connections and optional DIN-Rail mounting offer system designers the opportunity to eliminate the power board request in the field application.

Further features including high efficiency 86%; wide operating temp. range by -40°C to +92.5°C ; I/O isolation 3000VDC for 60Sec; no min. load request; built-in EMC filter for EMI emission EN 55032 class A and EMS immunity EN 61000-4-2,3,4,5,6,8 approved; and abnormal operation protection with under-voltage, overload and short circuit protections.

All family have been qualified per CB scheme with safety approvals to UL/cUL/IEC/EN 62368-1 with 3 years warranty.

Model Selection Guide

Model Number	Input Voltage (Range)	Output Voltage	Output Current	Input Current		Max. capacitive Load	Efficiency (typ.)
				Max.	@No Load		
	VDC	VDC	mA	@Max. Load mA(typ.)	@No Load mA(typ.)	μF	% @Max. Load
MKW110-24S05C	24 (9 ~ 36)	5	2000	496	30	1000	84
MKW110-24S051C		5.1	2000	506		1000	84
MKW110-24S12C		12	833	484		470	86
MKW110-24S15C		15	666	484		330	86
MKW110-24S24C		24	416	484		150	86
MKW110-24S48C		48	208	495		68	84
MKW110-24D12C		±12	±416	484		220#	86
MKW110-24D15C		±15	±333	484		150#	86
MKW110-24D24C		±24	±208	489		68#	85
MKW110-48S05C		48 (18 ~ 75)	5	2000		248	20
MKW110-48S051C	5.1		2000	253	1000	84	
MKW110-48S12C	12		833	242	470	86	
MKW110-48S15C	15		666	242	330	86	
MKW110-48S24C	24		416	242	150	86	
MKW110-48S48C	48		208	248	68	84	
MKW110-48D12C	±12		±416	242	220#	86	
MKW110-48D15C	±15		±333	242	150#	86	
MKW110-48D24C	±24		±208	245	68#	85	

For each output

Input Specifications						
Parameter	Conditions / Model	Min.	Typ.	Max.	Unit	
Input Surge Voltage (1 sec. max.)	24V Input Models	-0.7	---	50	VDC	
	48V Input Models	-0.7	---	100		
Start-Up Threshold Voltage	24V Input Models	---	---	9		
	48V Input Models	---	---	18		
Under Voltage Shutdown	24V Input Models	---	8	---		
	48V Input Models	---	16	---		
Start Up Time (Power On)	Nominal Vin and Constant Resistive Load	---	---	60	ms	
Input Filter	All Models	Internal Pi Type				

Remote On/Off Control						
Parameter	Conditions	Min.	Typ.	Max.	Unit	
Converter On	3.5V ~ 12V or Open Circuit					
Converter Off	0~1.2V or Short Circuit (Pin 1 and Pin 2)					
Control Input Current (on)	Vctrl = 5V	---	---	500	μA	
Control Input Current (off)	Vctrl = 0V	---	---	-500	μA	
Control Common	Referenced to Negative Input					
Standby Input Current	Nominal Vin	---	2.5	---	mA	

Output Specifications						
Parameter	Conditions / Model	Min.	Typ.	Max.	Unit	
Output Voltage Setting Accuracy		---	---	±2.0	%Vnom.	
Output Voltage Balance	Dual Output, Balanced Loads	---	±1.0	±2.0	%	
Line Regulation	Vin=Min. to Max. @Full Load	---	---	±0.5	%	
Load Regulation	Io=0% to 100%	---	---	±0.5	%	
Load Cross Regulation (Dual Output Models)	Asymmetrical Load 25/100% Full Load	---	---	±5.0	%	
Minimum Load	No minimum Load Requirement					
Ripple & Noise	0-20 MHz Bandwidth	24V & ±24V & 48V Output Models		---	180	mV _{P-P}
		Other Output Models		---	90	mV _{P-P}
Transient Recovery Time	25% Load Step Change	---	---	500	μsec	
Transient Response Deviation		---	±3	±5	%	
Temperature Coefficient		---	±0.01	±0.02	%/°C	
Over Load Protection	Hiccup	---	150	---	%	
Short Circuit Protection	Hiccup Mode 0.7Hz typ., Automatic Recovery					

General Specifications						
Parameter	Conditions	Min.	Typ.	Max.	Unit	
I/O Isolation Voltage	60 Seconds	3000	---	---	VDC	
I/O Isolation Resistance	500 VDC	1000	---	---	MΩ	
I/O Isolation Capacitance	100kHz, 1V	---	2200	---	pF	
Switching Frequency		---	330	---	kHz	
MTBF (calculated)	MIL-HDBK-217F@25°C, Ground Benign	4,132,899	---	---	Hours	
Safety Approvals	UL/cUL 62368-1 recognition(UL certificate), IEC/EN 62368-1 & 60950-1(CB report)					

Environmental Specifications			
Parameter	Min.	Max.	Unit
Operating Ambient Temperature Range (See Power Derating Curve)	-40	+92.5	°C
Case Temperature	---	+105	°C
Storage Temperature Range	-50	+125	°C
Humidity (non condensing)	---	95	% rel. H
Lead Temperature (1.5mm from case for 10Sec.)	---	260	°C

EMC Specifications

Parameter	Standards & Level		Performance	
EMI	Conduction & Radiation	EN 55032, FCC part 15	Class A	
EMS	EN55035			
	ESD	Direct discharge	Indirect discharge HCP & VCP	
		EN61000-4-2 Air ± 8kV	Contact ± 6kV	A
	Radiated immunity	EN61000-4-3 10V/m		A
	Fast transient	EN61000-4-4 ±2kV		A
	Surge	EN61000-4-5 ±2kV		A
	Conducted immunity	EN61000-4-6 10Vrms		A
PFMF	EN61000-4-8 100A/m		A	

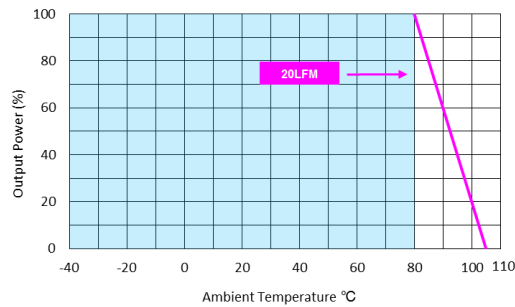
Power Derating Curve

Notes

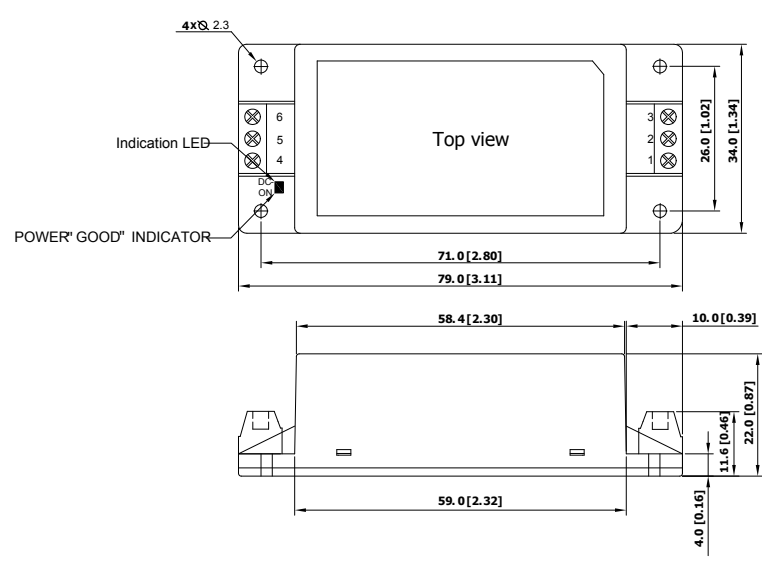
- 1 Specifications typical at Ta=+25°C, resistive load, nominal input voltage and rated output current unless otherwise noted.
- 2 Transient recovery time is measured to within 1% error band for a step change in output load of 75% to 100%
- 3 We recommend to protect the converter by a slow blow fuse in the input supply line.
- 4 Other input and output voltage may be available, please contact factory.
- 5 Specifications are subject to change without notice.

Package Specifications																						
Mechanical Dimensions 	Pin Connections <table border="1"> <thead> <tr> <th>Pin</th> <th>Single Output</th> <th>Dual Output</th> </tr> </thead> <tbody> <tr> <td>1</td> <td>Remote On/Off</td> <td>Remote On/Off</td> </tr> <tr> <td>2</td> <td>-Vin</td> <td>-Vin</td> </tr> <tr> <td>3</td> <td>+Vin</td> <td>+Vin</td> </tr> <tr> <td>4</td> <td>-Vout</td> <td>-Vout</td> </tr> <tr> <td>5</td> <td>NC</td> <td>Common</td> </tr> <tr> <td>6</td> <td>+Vout</td> <td>+Vout</td> </tr> </tbody> </table> <p>NC: No Connection</p> <p>▶ All dimensions in mm (inches) ▶ Tolerance: X.X±0.5 (X.XX±0.02) X.XX±0.25 (X.XXX±0.01)</p>	Pin	Single Output	Dual Output	1	Remote On/Off	Remote On/Off	2	-Vin	-Vin	3	+Vin	+Vin	4	-Vout	-Vout	5	NC	Common	6	+Vout	+Vout
Pin	Single Output	Dual Output																				
1	Remote On/Off	Remote On/Off																				
2	-Vin	-Vin																				
3	+Vin	+Vin																				
4	-Vout	-Vout																				
5	NC	Common																				
6	+Vout	+Vout																				

Physical Characteristics	
Case Size	: 79.0x34.0x22.0mm (3.11x1.10x0.87 inches)
Case Material	: Plastic resin (flammability to UL 94V-0 rated)
Weight	: 65.76g

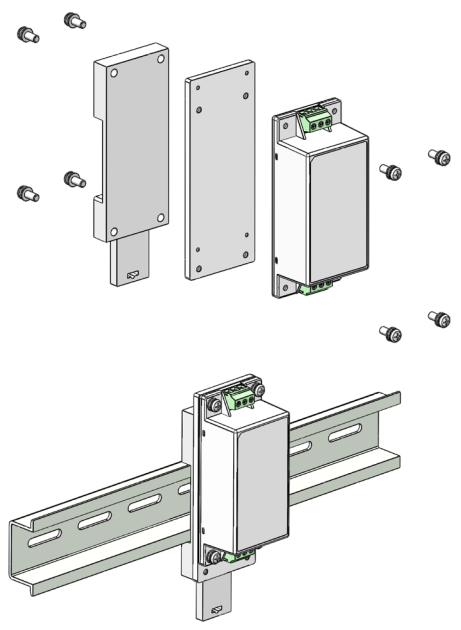
Package Specifications with DIN Rail Mounting Bracket (order code AC-DIN-05)

Mechanical Dimensions	DIN-Rail Mounting Kit
	

Physical Characteristics

Case Size	: 79.0x34.0x22.0mm (3.11x1.10x0.87 inches)
Case Material	: Plastic resin (flammability to UL 94V-0 rated)
Weight	: 108.76g

Order Code Table

Standard	DIN Rail	Converter With DIN Rail Mounting
MKW110-24S05C	AC-DIN05	MKW110-24S05C-DIN05
MKW110-24S051C	AC-DIN05	MKW110-24S051C-DIN05
MKW110-24S12C	AC-DIN05	MKW110-24S12C-DIN05
MKW110-24S15C	AC-DIN05	MKW110-24S15C-DIN05
MKW110-24S24C	AC-DIN05	MKW110-24S24C-DIN05
MKW110-24S48C	AC-DIN05	MKW110-24S48C-DIN05
MKW110-24D12C	AC-DIN05	MKW110-24D12C-DIN05
MKW110-24D15C	AC-DIN05	MKW110-24D15C-DIN05
MKW110-24D24C	AC-DIN05	MKW110-24D24C-DIN05
MKW110-48S05C	AC-DIN05	MKW110-48S05C-DIN05
MKW110-48S051C	AC-DIN05	MKW110-48S051C-DIN05
MKW110-48S12C	AC-DIN05	MKW110-48S12C-DIN05
MKW110-48S15C	AC-DIN05	MKW110-48S15C-DIN05
MKW110-48S24C	AC-DIN05	MKW110-48S24C-DIN05
MKW110-48S48C	AC-DIN05	MKW110-48S48C-DIN05
MKW110-48D12C	AC-DIN05	MKW110-48D12C-DIN05
MKW110-48D15C	AC-DIN05	MKW110-48D15C-DIN05
MKW110-48D24C	AC-DIN05	MKW110-48D24C-DIN05

Test Setup
Peak-to-Peak Output Noise Measurement Test

Use a Cout 0.47µF ceramic capacitor. Scope measurement should be made by using a BNC socket, measurement bandwidth is 0-20 MHz. Position the load between 50 mm and 75 mm from the DC-DC Converter.

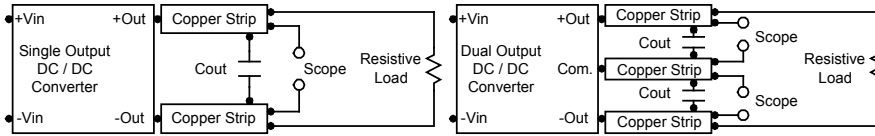
Technical Notes
Remote On/Off

Positive logic remote on/off turns the module on during a logic high voltage on the remote on/off pin, and off during a logic low. To turn the power module on and off, the user must supply a switch to control the voltage between the on/off terminal and the -Vin terminal. The switch can be an open collector or equivalent. A logic low is 0V to 1.2V. A logic high is 3.5V to 12V. The maximum sink current at the on/off terminal (Pin 1) during a logic low is -500µA.

Overload Protection

To provide protection in a fault (output overload) condition, the unit is equipped with internal current limiting circuitry and can endure current limiting for an unlimited duration. At the point of current-limit inception, the unit shifts from voltage control to current control. The unit operates normally once the output current is brought back into its specified range.

Input Source Impedance

The power module should be connected to a low ac-impedance input source. Highly inductive source impedances can affect the stability of the power module. In applications where power is supplied over long lines and output loading is high, it may be necessary to use a capacitor at the input to ensure startup. By using a good quality low Equivalent Series Resistance (ESR < 1.0Ω at 100 kHz) capacitor of a 4.7µF for the 24V input devices and a 2.2µF for the 48V devices, capacitor mounted close to the power module helps ensure stability of the unit.

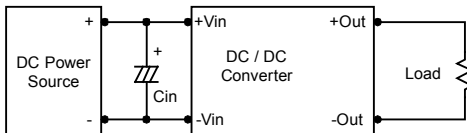
Output Ripple Reduction

A good quality low ESR capacitor placed as close as practicable across the load will give the best ripple and noise performance. To reduce output ripple, it is recommended to use 3.3µF capacitors at the output.

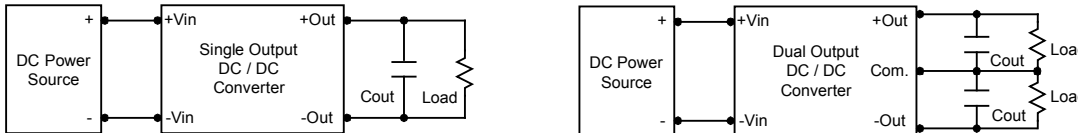
Maximum Capacitive Load

The MKW110C series has limitation of maximum connected capacitance on the output. The power module may operate in current limiting mode during start-up, affecting the ramp-up and the startup time. The maximum capacitance can be found in the data sheet.

Thermal Considerations

Many conditions affect the thermal performance of the power module, such as orientation, airflow over the module and board spacing. To avoid exceeding the maximum temperature rating of the components inside the power module, the case temperature must be kept below 105°C.

The derating curves are determined from measurements obtained in a test setup.

