



MINMAX[®]

MKW50 Series

Electric Characteristic Note

MKW50 Series EC Note

DC-DC CONVERTER 50W, Highest Power Density

Features

- ▶ Smallest Encapsulated 50W Converter
- ▶ Ultra-compact 2" X 1" Package
- ▶ Wide 2:1 Input Voltage Range
- ▶ Fully Regulated Output Voltage
- ▶ Excellent Efficiency up to 92%
- ▶ I/O Isolation 1500 VDC
- ▶ Operating Ambient Temp. Range -40°C to +80°C
- ▶ No Min. Load Requirement
- ▶ Overload/Voltage/Temp. and Short Circuit Protection
- ▶ Remote On/Off Control, Output Voltage Trim
- ▶ Shielded Metal Case with Insulated Baseplate
- ▶ UL/cUL/IEC/EN 62368-1(60950-1) Safety Approval & CE Marking

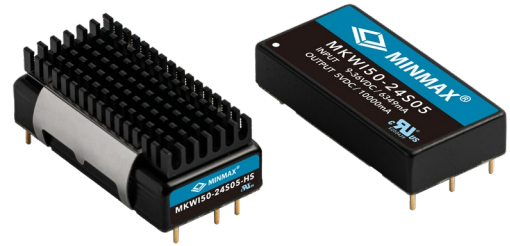

Applications

- ▶ Distributed power architectures
- ▶ Workstations
- ▶ Computer equipment
- ▶ Communications equipment

Product Overview

The MINMAX MKW50 series is the latest generation of high performance DC-DC converter modules setting a new standard concerning power density. The product offers fully 50W in an encapsulated, shielded metal package with dimensions of just 2.0"x1.0"x0.4". All models provide wide 2:1 input voltage range and precisely regulated output voltages.

Advanced circuit topology provides a very high efficiency up to 92% which allows an operating temperature range of -40°C to +80°C. Further features include remote On/Off, trimmable output voltage, under-voltage shutdown as well as overload and over-temperature protection. Typical applications for these converters are battery operated equipment, instrumentation, distributed power architectures in communication and industrial electronics and many other space critical applications.

Table of contents

Model Selection Guide	P2	External Output Trimming.....	P21
Input Specifications.....	P2	Test Setup.....	P22
Remote On/Off Control	P2	Technical Notes	P22
Output Specifications.....	P3	Remote ON/OFF Implementation.....	P23
General Specifications.....	P3	Packaging Information.....	P23
EMC Specifications.....	P3	Wave Soldering Considerations	P24
Environmental Specifications	P4	Hand Welding Parameter	P24
Characteristic Curves	P5	Part Number Structure	P25
Package Specifications	P20	MTBF and Reliability	P25
Recommended Pad Layout.....	P20		

Model Selection Guide

Model Number	Input Voltage (Range)	Output Voltage	Output Current	Input Current		Reflected Ripple Current	Over Voltage Protection	Max. capacitive Load	Efficiency (typ.)
				Max.	@No Load				@Max. Load
	VDC	VDC	mA	mA(typ.)	mA(typ.)	mA(typ.)	VDC	µF	%
MKW50-12S033	12 (9 ~ 18)	3.3	10000	3090	85	50	3.9	25800	89
MKW50-12S05		5	10000	4630	110		6.2	17000	90
MKW50-12S12		12	4170	4580	160		15	2900	91
MKW50-12S15		15	3330	4580	160		18	1900	91
MKW50-12S24		24	2080	4570	250		30	750	91
MKW50-24S033	24 (18 ~ 36)	3.3	10000	1550	50	40	3.9	25800	89
MKW50-24S05		5	10000	2260	70		6.2	17000	92
MKW50-24S12		12	4170	2260	85		15	2900	92
MKW50-24S15		15	3330	2260	85		18	1900	92
MKW50-24S24		24	2080	2290	110		30	750	91
MKW50-48S033	48 (36 ~ 75)	3.3	10000	770	35	30	3.9	25800	89
MKW50-48S05		5	10000	1130	45		6.2	17000	92
MKW50-48S12		12	4170	1130	50		15	2900	92
MKW50-48S15		15	3330	1130	50		18	1900	92
MKW50-48S24		24	2080	1150	60		30	750	91

Input Specifications

Parameter	Model	Min.	Typ.	Max.	Unit
Input Surge Voltage (100ms. max)	12V Input Models	-0.7	---	25	VDC
	24V Input Models	-0.7	---	50	
	48V Input Models	-0.7	---	100	
Start-Up Threshold Voltage	12V Input Models	---	---	9	
	24V Input Models	---	---	18	
	48V Input Models	---	---	36	
Under Voltage Shutdown	12V Input Models	---	8.3	---	
	24V Input Models	---	16.5	---	
	48V Input Models	---	33	---	
Start Up Time	Power Up	---	---	30	ms
	Remote On/Off	Nominal Vin and Constant Resistive Load	---	---	30
Input Filter	All Models	Internal LC Type			

Remote On/Off Control

Parameter	Conditions	Min.	Typ.	Max.	Unit
Converter On	3.5V ~ 12V or Open Circuit				
Converter Off	0V ~ 1.2V or Short Circuit				
Control Input Current (on)	Vctrl = 5.0V	---	0.5	---	mA
Control Input Current (off)	Vctrl = 0V	---	-0.5	---	mA
Control Common	Referenced to Negative Input				
Standby Input Current	Nominal Vin	---	2.5	---	mA

Output Specifications

Parameter	Conditions / Model		Min.	Typ.	Max.	Unit
Output Voltage Setting Accuracy			---	---	±1.0	%Vnom.
Line Regulation	Vin=Min. to Max. @ Full Load		---	---	±0.5	%
Load Regulation	Io=0% to 100%		---	---	±0.5	%
Minimum Load	No minimum Load Requirement					
Ripple & Noise	0-20 MHz Bandwidth	3.3V & 5V Models ⁽³⁾	---	---	100	mV _{P-P}
		12V, 15V & 24V Models ⁽³⁾	---	---	150	mV _{P-P}
Transient Recovery Time	25% Load Step Change ⁽²⁾		---	250	---	μsec
Transient Response Deviation			---	±3	±5	%
Temperature Coefficient			---	---	±0.02	%/°C
Trim Up / Down Range (See Page 6)	% of Nominal Output Voltage	24Vo Models	---	---	+20 / -10	%
		Other Models	---	---	±10	%
Over Load Protection	Hiccup		---	150	---	%
Short Circuit Protection	24Vo Models		Continuous, Automatic Recovery (Hiccup Mode 0.3Hz typ.)			
	Other Models		Continuous, Automatic Recovery (Hiccup Mode 1.5Hz typ.)			

General Specifications

Parameter	Conditions / Model	Min.	Typ.	Max.	Unit
I/O Isolation Voltage	60 Seconds	1500	---	---	VDC
	1 Second	1800	---	---	VDC
I/O Isolation Resistance	500 VDC	1000	---	---	MΩ
I/O Isolation Capacitance	100kHz, 1V	---	---	2200	pF
Switching Frequency	24Vo Models	---	285	---	kHz
	Other Models	---	320	---	kHz
MTBF(calculated)	MIL-HDBK-217F@25°C, Ground Benign	224,700			Hours
Safety Approvals	UL/cUL 60950-1 recognition(CSA certificate), IEC/EN 60950-1(CB-report)				
	UL/cUL 62368-1 recognition(UL certificate), IEC/EN 62368-1(CB-report)				

EMC Specifications

Parameter	Standards & Level			Performance	
	Conduction	Radiation	EN 55032		
EMI _(e)			EN 55032	With external components	Class A
EMS _(e)	EN 55024				
	ESD	EN61000-4-2 Air ± 8kV , Contact ± 6kV			A
	Radiated immunity	EN61000-4-3 10V/m			A
	Fast transient	EN61000-4-4 ±2kV			A
	Surge	EN61000-4-5 ±1kV			A
	Conducted immunity	EN61000-4-6 10Vrms			A

Environmental Specifications					
Parameter	Conditions / Model	Min.	Max.		Unit
			without Heatsink	with Heatsink	
Operating Ambient Temperature Range Nominal Vin, Load 100% Inom. (for Power Derating see relative Derating Curves)	MKW50-XXS033	-40	56	64	°C
	MKW50-24S05, MKW50-24S12		53	62	
	MKW50-24S15, MKW50-48S05				
	MKW50-48S12, MKW50-48S15				
	MKW50-12S12, MKW50-12S15		46	56	
	MKW50-12S24, MKW50-24S24				
	MKW50-48S24		38	49	
MKW50-12S05					
Thermal Impedance	20LFM Convection without Heatsink	12.1	---	---	°C/W
	20LFM Convection with Heatsink	9.8	---	---	°C/W
	100LFM Convection without Heatsink	9.2	---	---	°C/W
	100LFM Convection with Heatsink	5.4	---	---	°C/W
	200LFM Convection without Heatsink	7.8	---	---	°C/W
	200LFM Convection with Heatsink	4.5	---	---	°C/W
	400LFM Convection without Heatsink	5.2	---	---	°C/W
	400LFM Convection with Heatsink	3.0	---	---	°C/W
Case Temperature		---	+105		°C
Thermal Protection	Shutdown Temperature		110°C typ.		
Storage Temperature Range		-50	+125		°C
Humidity (non condensing)		---	95		% rel. H
RFI	Six-Sided Shielded, Metal Case				
Lead Temperature (1.5mm from case for 10Sec.)		---	260		°C

Notes

- 1 Specifications typical at Ta=+25°C, resistive load, nominal input voltage and rated output current unless otherwise noted.
- 2 Transient recovery time is measured to within 1% error band for a step change in output load of 75% to 100%.
- 3 Ripple & Noise measurement with a 1µF/50V MLCC and a 10µF/50V Tantalum Capacitor.
- 4 We recommend to protect the converter by a slow blow fuse in the input supply line.
- 5 Other input and output voltage may be available, please contact MINMAX.
- 6 The external components might be required to meet EMI/EMS standard for some of test items. Please contact MINMAX for the solution in detail.
- 7 Do not exceed maximum power specification when adjusting output voltage.
- 8 Specifications are subject to change without notice.

Characteristic Curves

All test conditions are at 25°C The figures are identical for MKW50-12S033

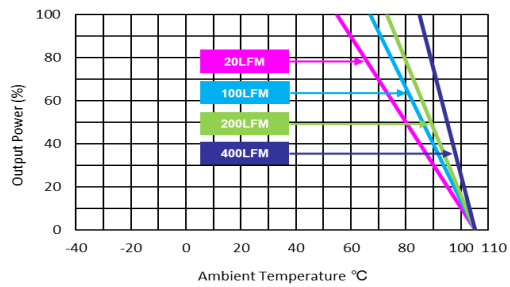
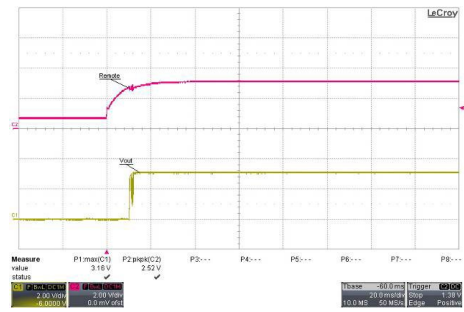
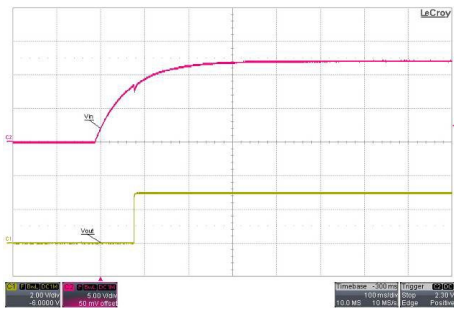
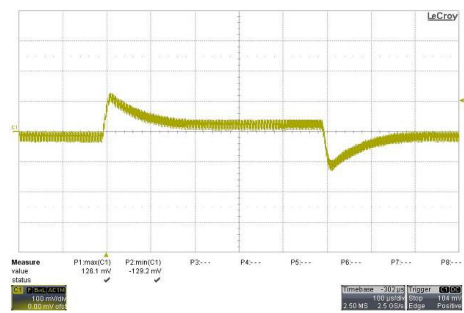
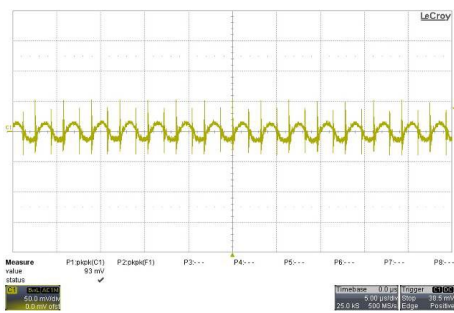
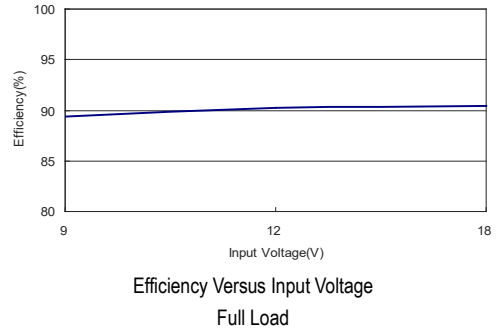
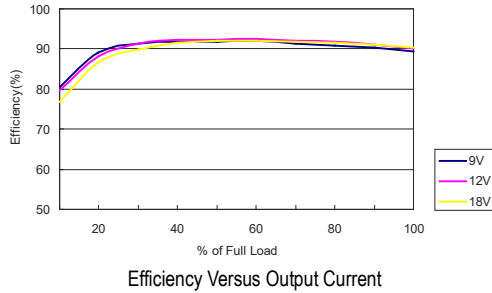

Characteristic Curves

All test conditions are at 25°C The figures are identical for MKW50-12S05

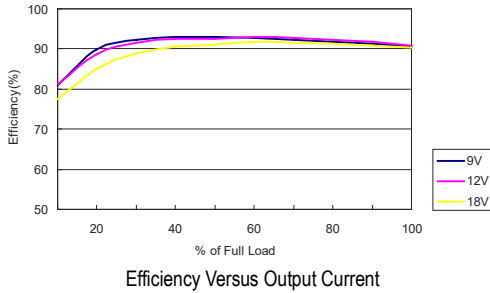

Efficiency Versus Output Current

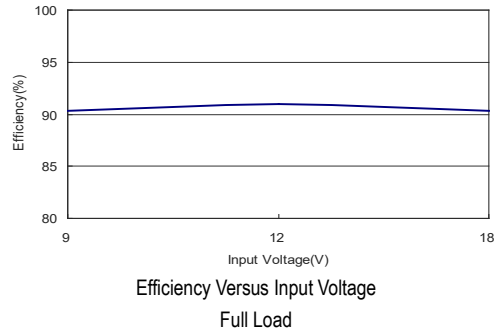

Efficiency Versus Input Voltage Full Load

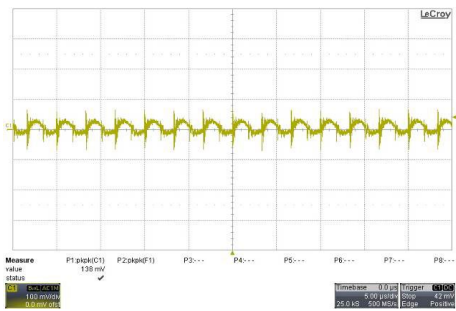

Typical Output Ripple and Noise
 $V_{in}=V_{in nom}$; Full Load

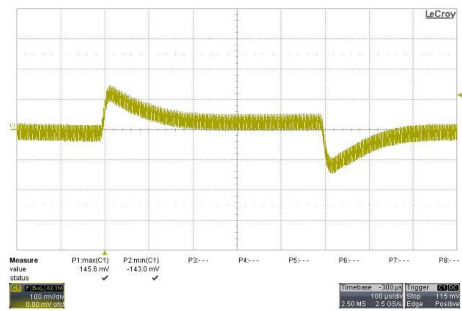

Transient Response to Dynamic Load Change
from 100% to 75% of Full Load ; $V_{in}=V_{in nom}$

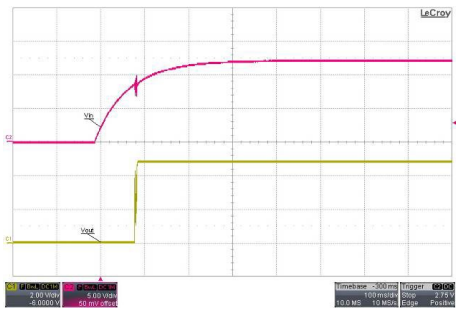

Typical Input Start-Up and Output Rise Characteristic
 $V_{in}=V_{in nom}$; Full Load

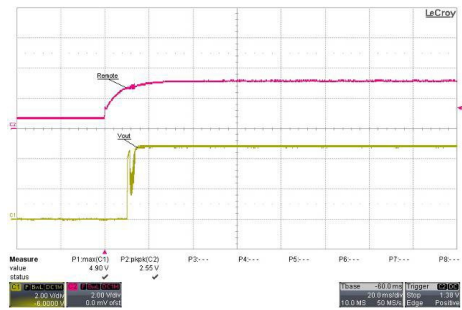

ON/OFF Voltage Start-Up and Output Rise Characteristic
 $V_{in}=V_{in nom}$; Full Load

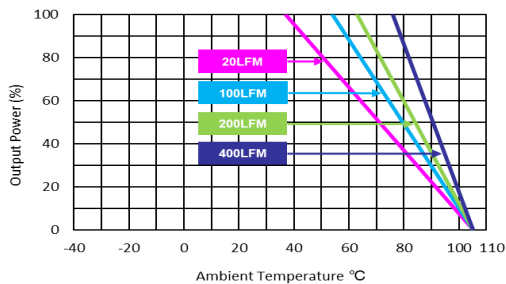

Derating Output Current Versus Ambient Temperature
 $V_{in}=V_{in nom}$

Characteristic Curves

All test conditions are at 25°C The figures are identical for MKW50-12S12

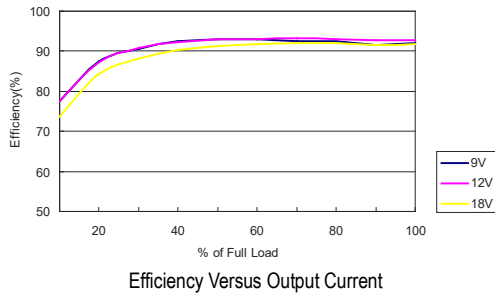

Efficiency Versus Output Current

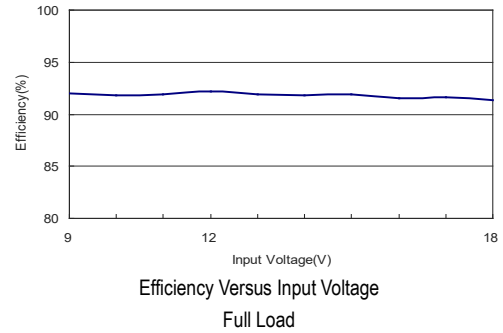

Efficiency Versus Input Voltage Full Load

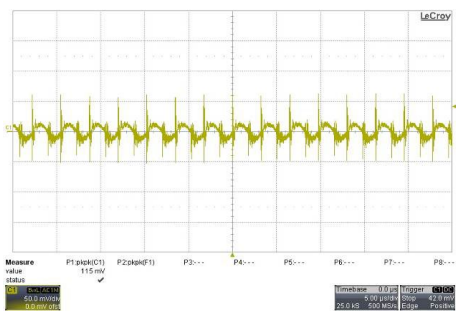

Typical Output Ripple and Noise
 $V_{in}=V_{in nom}$; Full Load

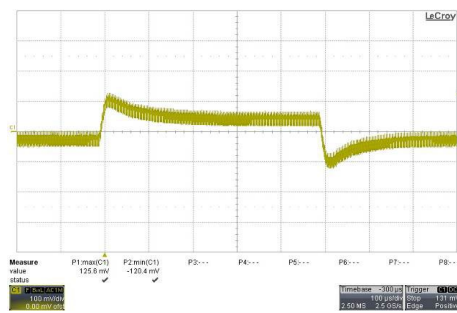

Transient Response to Dynamic Load Change
from 100% to 75% of Full Load ; $V_{in}=V_{in nom}$

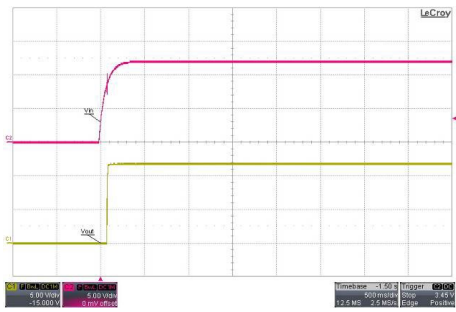

Typical Input Start-Up and Output Rise Characteristic
 $V_{in}=V_{in nom}$; Full Load

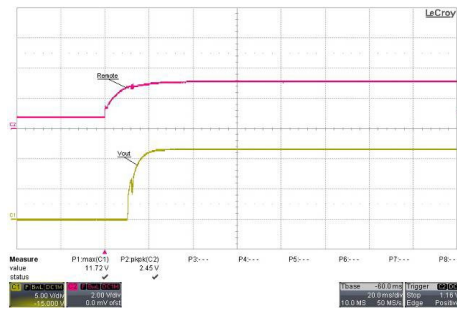

ON/OFF Voltage Start-Up and Output Rise Characteristic
 $V_{in}=V_{in nom}$; Full Load

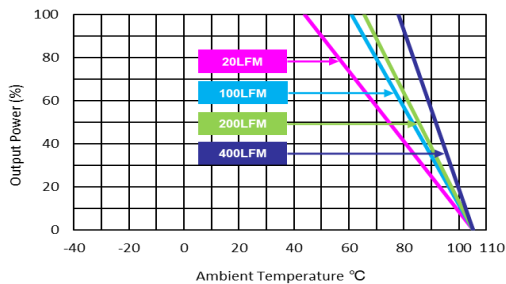

Derating Output Current Versus Ambient Temperature
 $V_{in}=V_{in nom}$

Characteristic Curves

All test conditions are at 25°C The figures are identical for MKW50-12S15

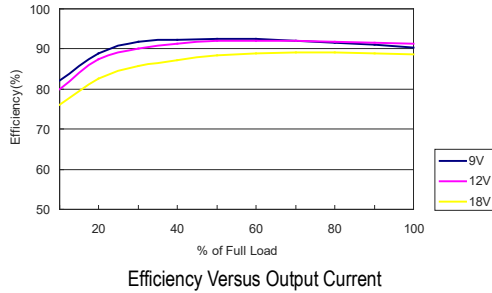

Efficiency Versus Output Current

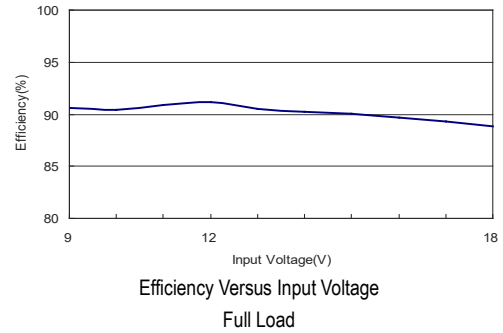

Efficiency Versus Input Voltage Full Load

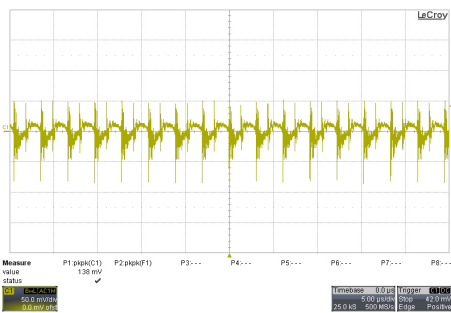

Typical Output Ripple and Noise
 $V_{in}=V_{in\ nom}$; Full Load

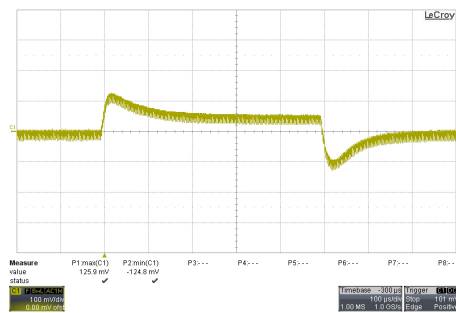

Transient Response to Dynamic Load Change
from 100% to 75% of Full Load ; $V_{in}=V_{in\ nom}$

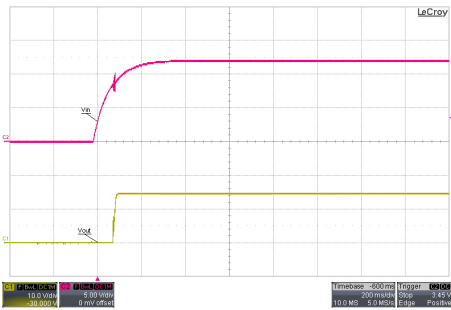

Typical Input Start-Up and Output Rise Characteristic
 $V_{in}=V_{in\ nom}$; Full Load

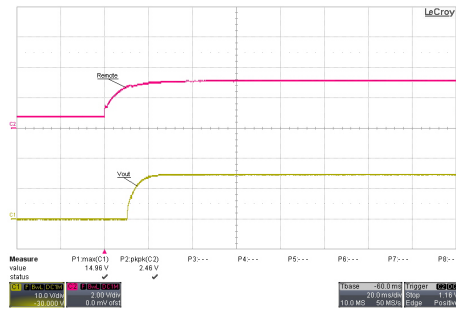

ON/OFF Voltage Start-Up and Output Rise Characteristic
 $V_{in}=V_{in\ nom}$; Full Load

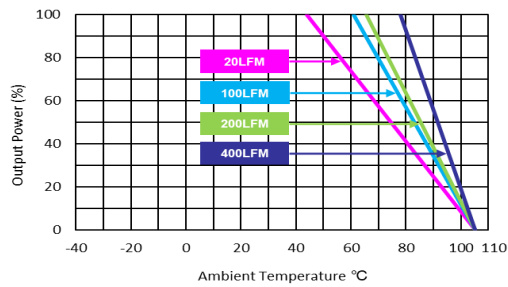

Derating Output Current Versus Ambient Temperature
 $V_{in}=V_{in\ nom}$

Characteristic Curves

All test conditions are at 25°C The figures are identical for MKW50-12S24

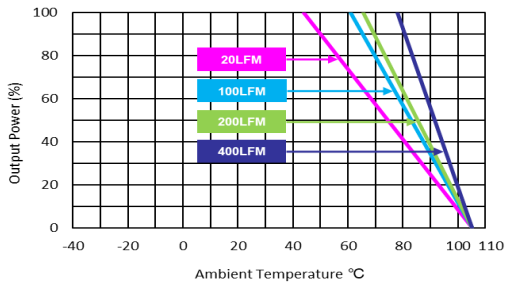
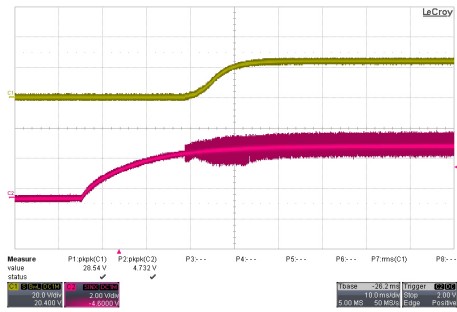
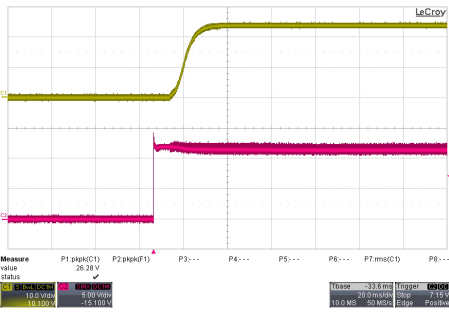
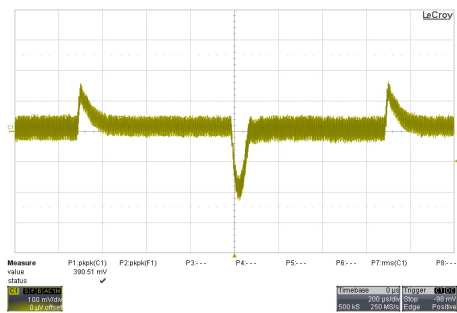
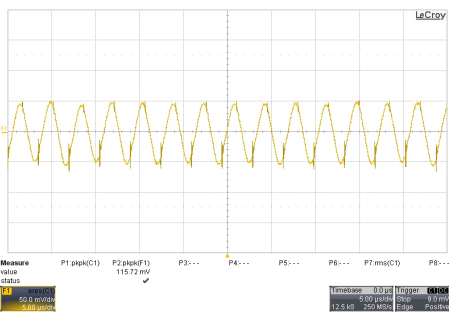
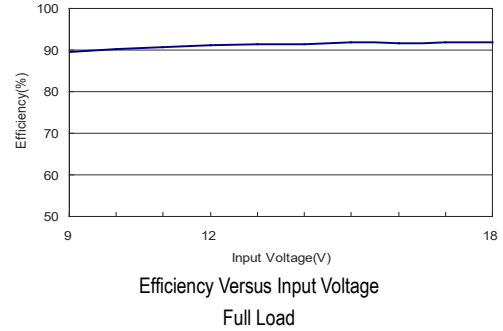
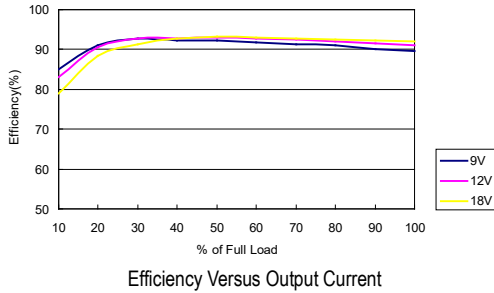

Characteristic Curves

All test conditions are at 25°C The figures are identical for MKW50-24S033

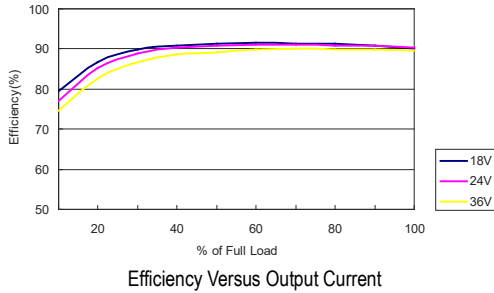

Efficiency Versus Output Current

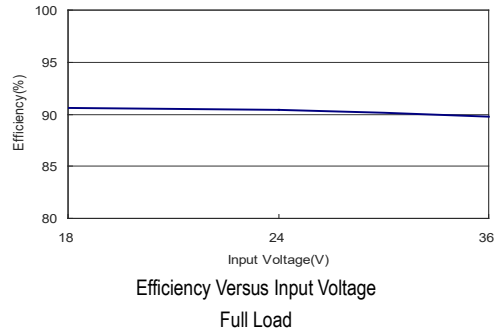

Efficiency Versus Input Voltage Full Load

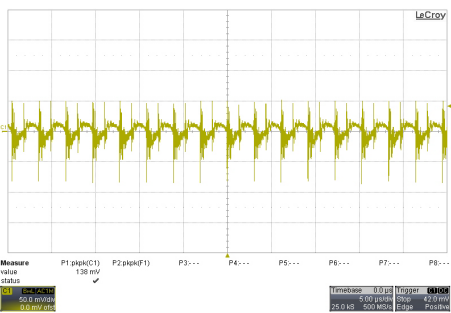

Typical Output Ripple and Noise
 $V_{in}=V_{in\ nom}$; Full Load

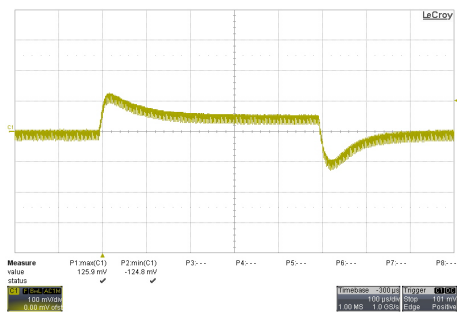

Transient Response to Dynamic Load Change
from 100% to 75% of Full Load ; $V_{in}=V_{in\ nom}$

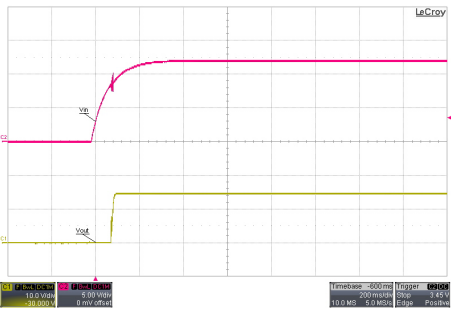

Typical Input Start-Up and Output Rise Characteristic
 $V_{in}=V_{in\ nom}$; Full Load

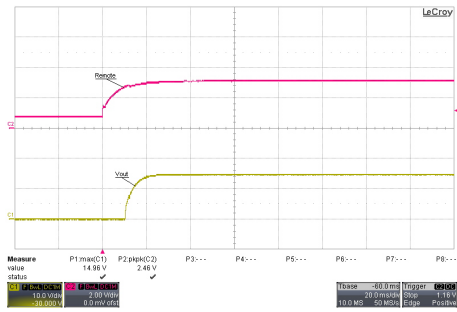

ON/OFF Voltage Start-Up and Output Rise Characteristic
 $V_{in}=V_{in\ nom}$; Full Load

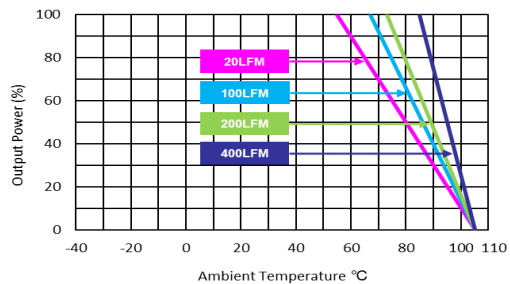

Derating Output Current Versus Ambient Temperature
 $V_{in}=V_{in\ nom}$

Characteristic Curves

All test conditions are at 25°C The figures are identical for MKW50-24S05

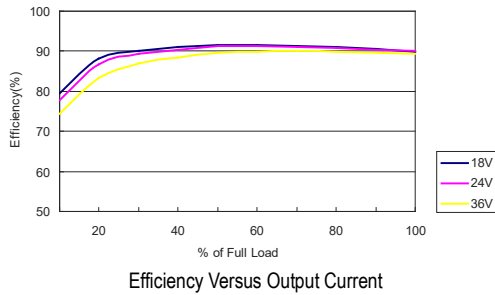

Efficiency Versus Output Current

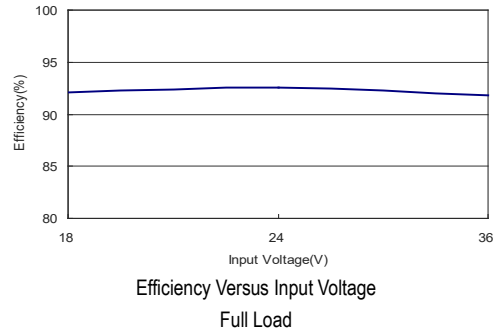

Efficiency Versus Input Voltage Full Load

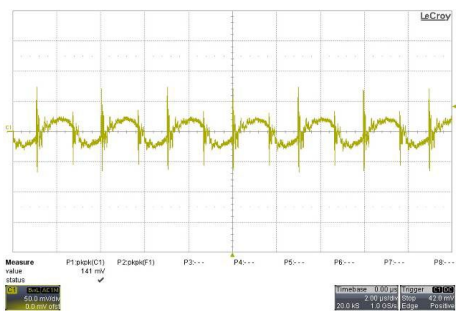

Typical Output Ripple and Noise
 $V_{in}=V_{in nom}$; Full Load

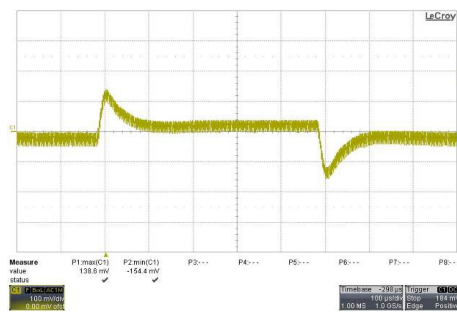

Transient Response to Dynamic Load Change
from 100% to 75% of Full Load ; $V_{in}=V_{in nom}$

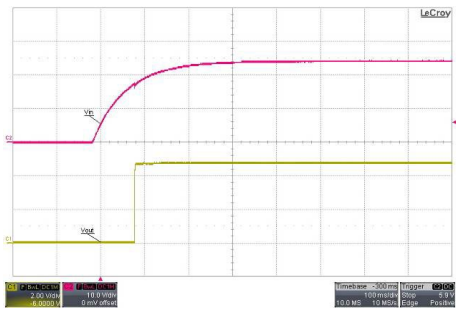

Typical Input Start-Up and Output Rise Characteristic
 $V_{in}=V_{in nom}$; Full Load

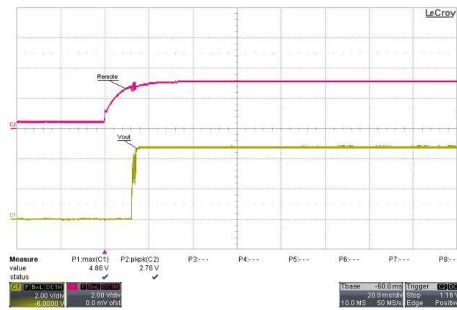

ON/OFF Voltage Start-Up and Output Rise Characteristic
 $V_{in}=V_{in nom}$; Full Load

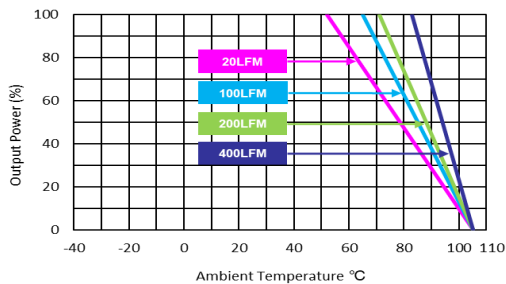

Derating Output Current Versus Ambient Temperature
 $V_{in}=V_{in nom}$

Characteristic Curves

All test conditions are at 25°C The figures are identical for MKW50-24S12

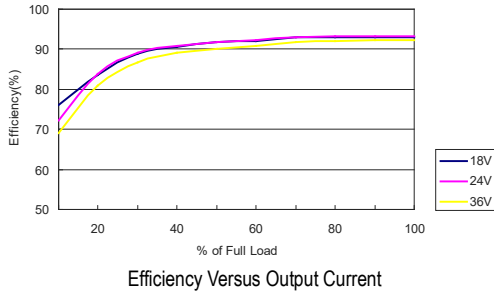

Efficiency Versus Output Current

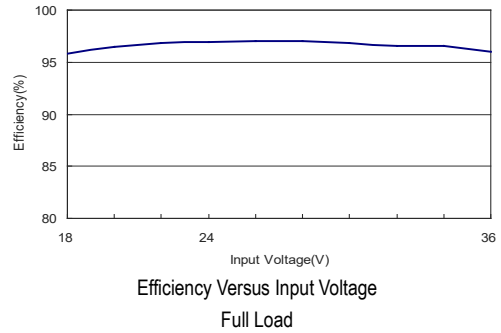

Efficiency Versus Input Voltage Full Load

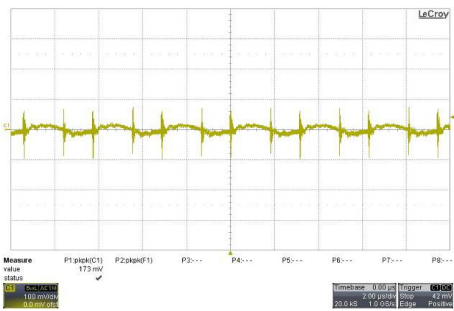

Typical Output Ripple and Noise
 $V_{in}=V_{in\ nom}$; Full Load

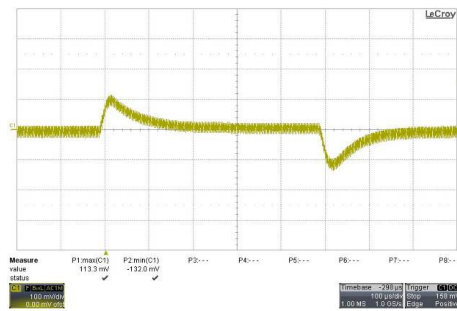

Transient Response to Dynamic Load Change
from 100% to 75% of Full Load ; $V_{in}=V_{in\ nom}$

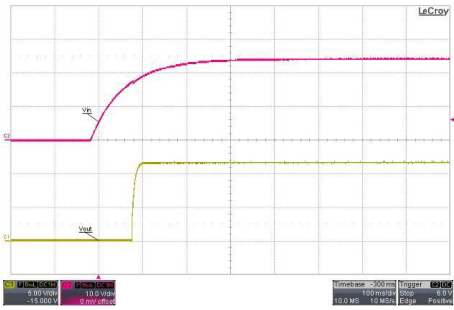

Typical Input Start-Up and Output Rise Characteristic
 $V_{in}=V_{in\ nom}$; Full Load

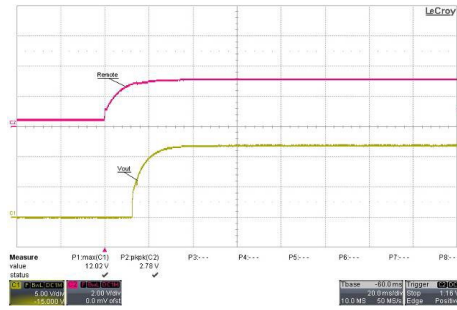

ON/OFF Voltage Start-Up and Output Rise Characteristic
 $V_{in}=V_{in\ nom}$; Full Load

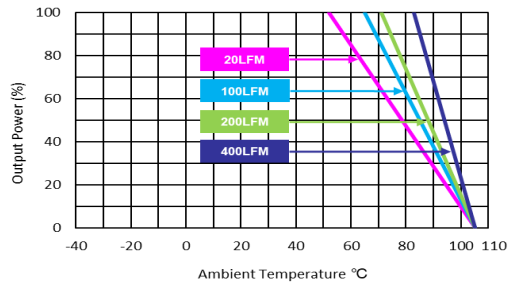

Derating Output Current Versus Ambient Temperature
 $V_{in}=V_{in\ nom}$

Characteristic Curves

All test conditions are at 25°C The figures are identical for MKW50-24S15

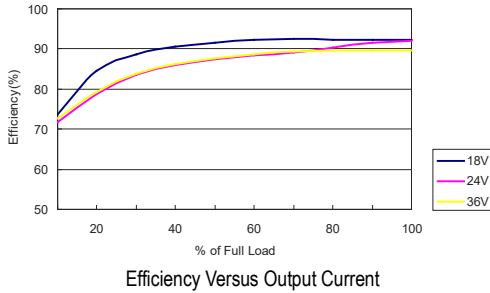

Efficiency Versus Output Current

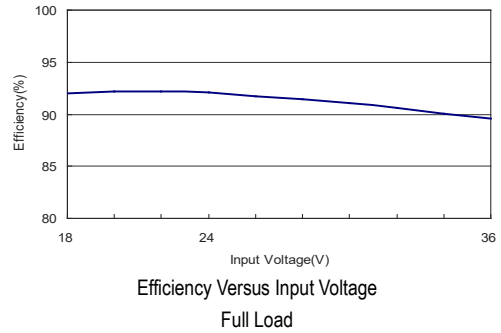

Efficiency Versus Input Voltage Full Load

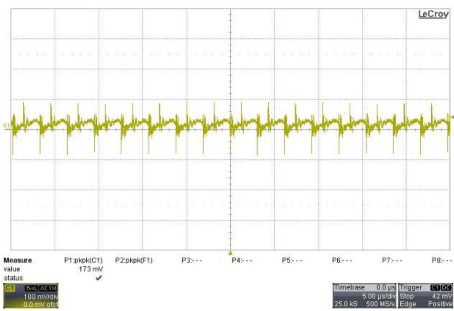

Typical Output Ripple and Noise
 $V_{in}=V_{in nom}$; Full Load

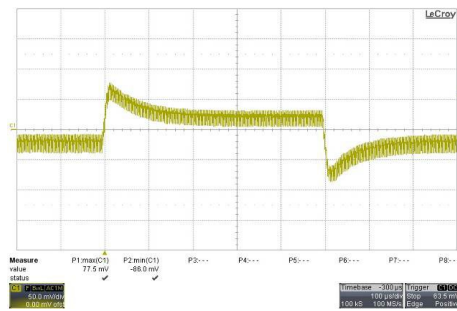

Transient Response to Dynamic Load Change
from 100% to 75% of Full Load ; $V_{in}=V_{in nom}$

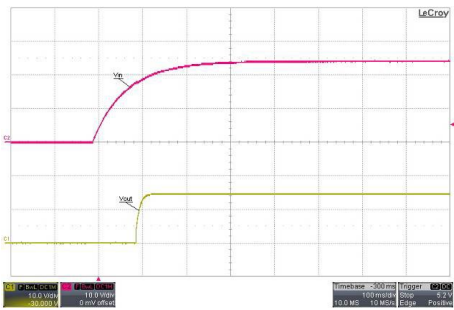

Typical Input Start-Up and Output Rise Characteristic
 $V_{in}=V_{in nom}$; Full Load

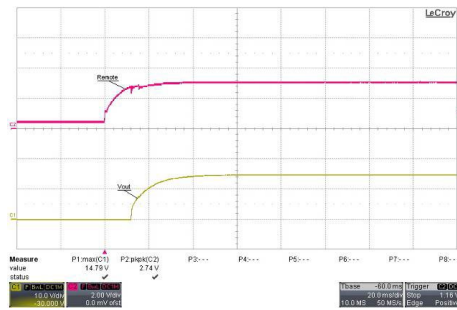

ON/OFF Voltage Start-Up and Output Rise Characteristic
 $V_{in}=V_{in nom}$; Full Load

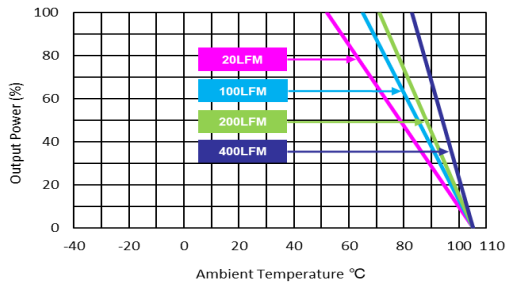

Derating Output Current Versus Ambient Temperature
 $V_{in}=V_{in nom}$

Characteristic Curves

All test conditions are at 25°C The figures are identical for MKW50-24S24

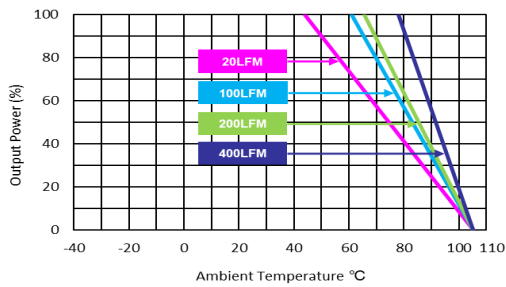
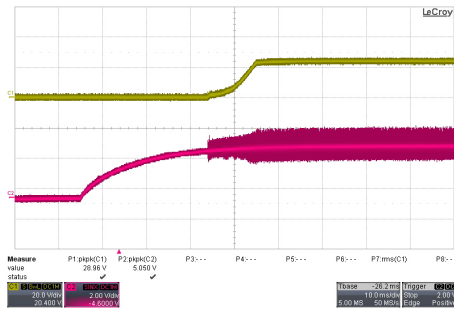
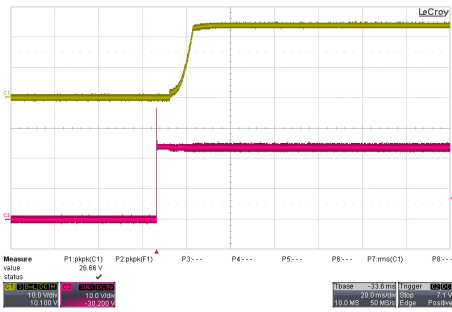
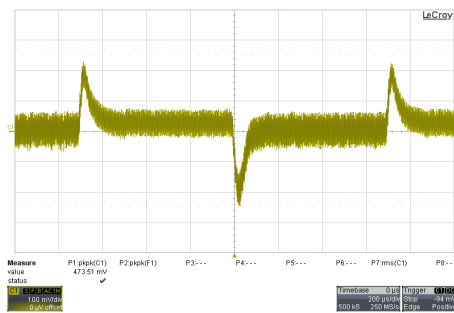
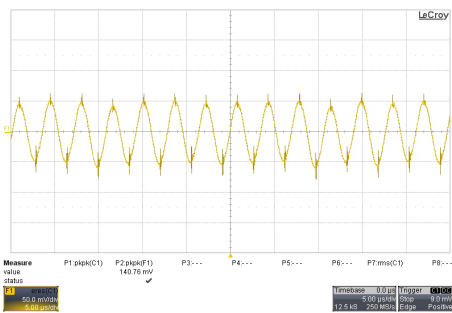
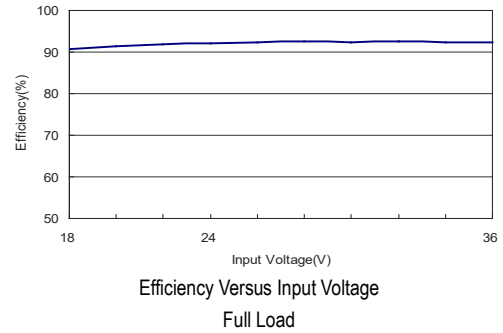
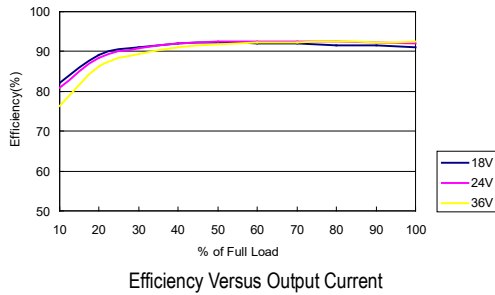

Characteristic Curves

All test conditions are at 25°C The figures are identical for MKW50-48S033

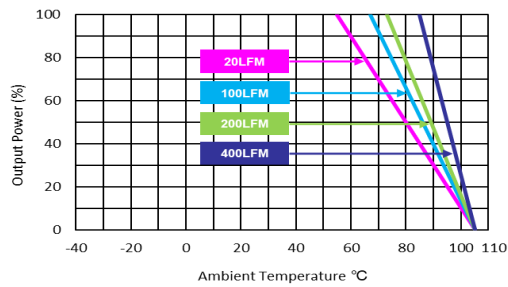
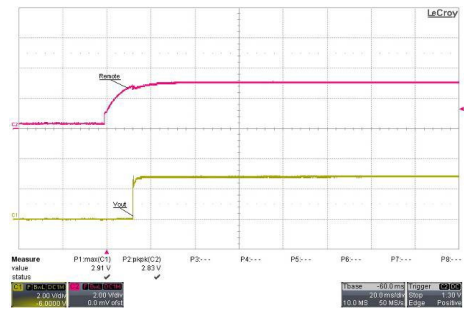
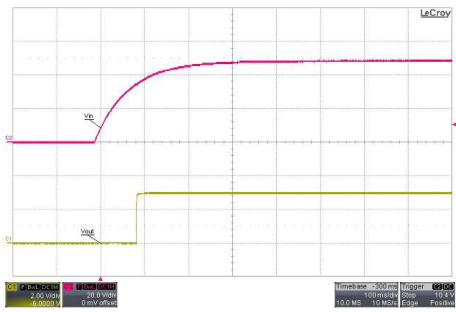
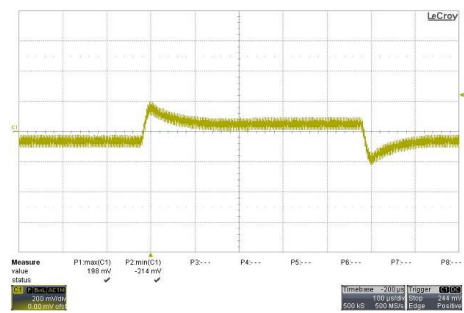
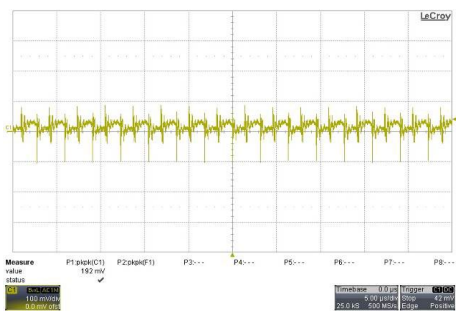
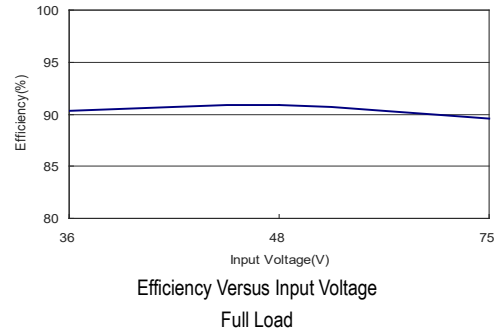
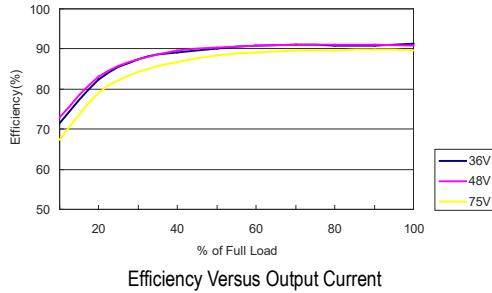

Characteristic Curves

All test conditions are at 25°C The figures are identical for MKW50-48S05

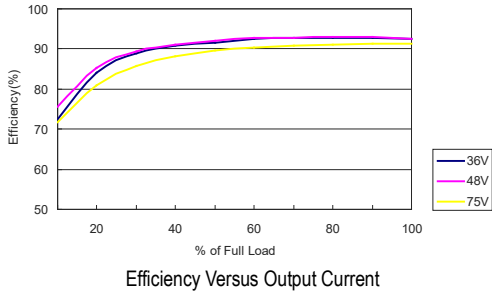

Efficiency Versus Output Current

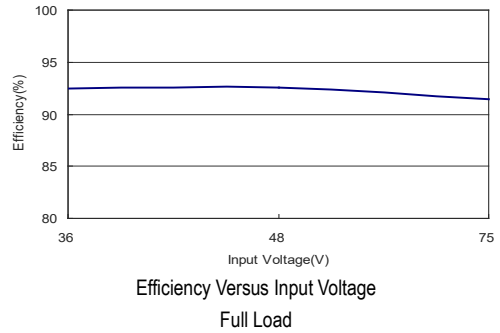

Efficiency Versus Input Voltage Full Load

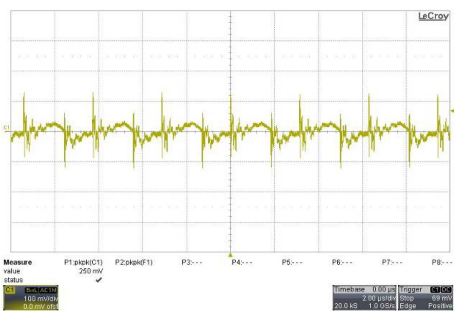

Typical Output Ripple and Noise
 $V_{in}=V_{in\ nom}$; Full Load

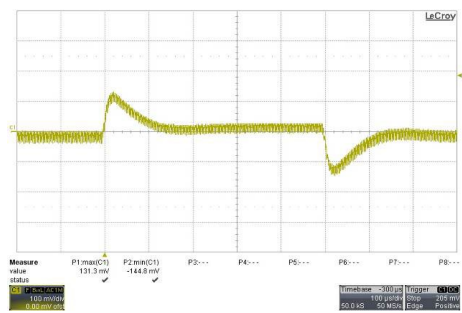

Transient Response to Dynamic Load Change
from 100% to 75% of Full Load ; $V_{in}=V_{in\ nom}$

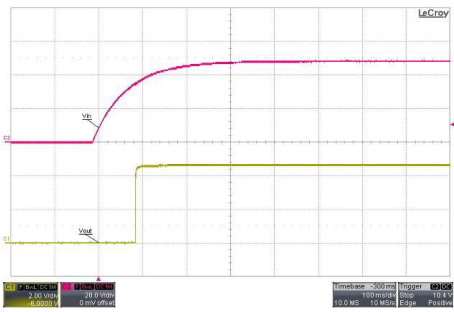

Typical Input Start-Up and Output Rise Characteristic
 $V_{in}=V_{in\ nom}$; Full Load

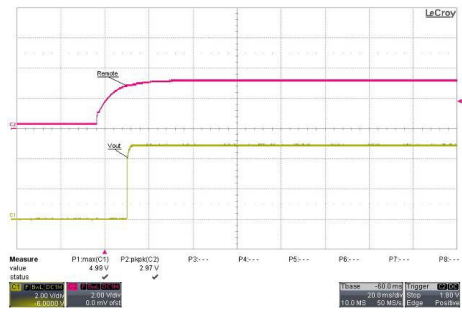

ON/OFF Voltage Start-Up and Output Rise Characteristic
 $V_{in}=V_{in\ nom}$; Full Load

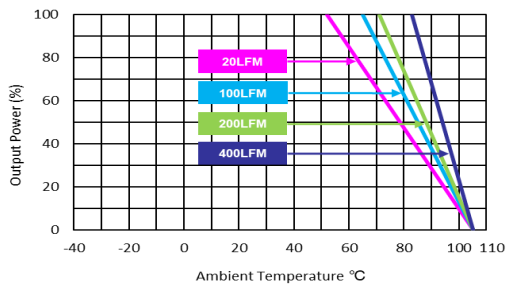

Derating Output Current Versus Ambient Temperature
 $V_{in}=V_{in\ nom}$

Characteristic Curves

All test conditions are at 25°C The figures are identical for MKW50-48S12

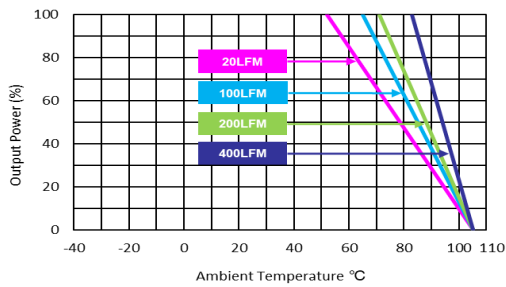
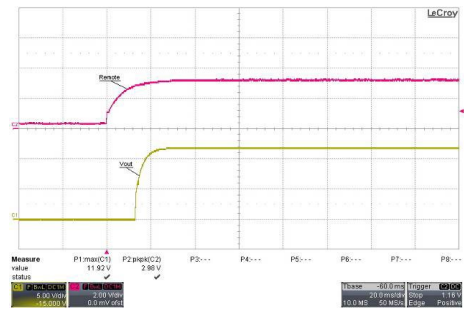
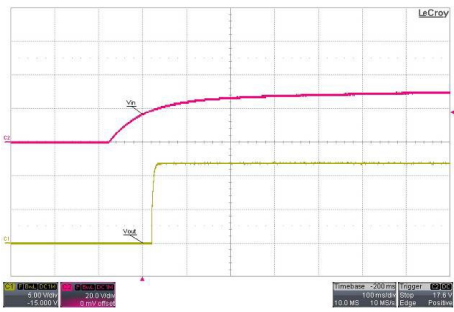
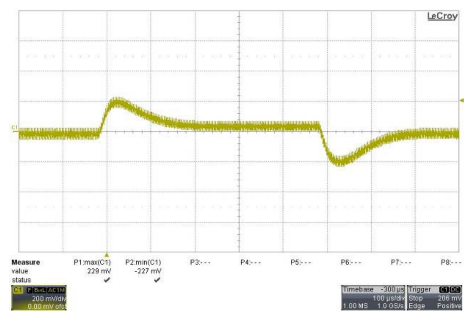
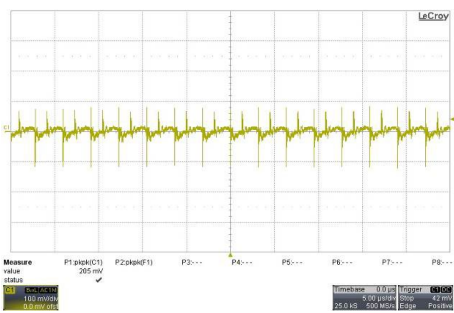
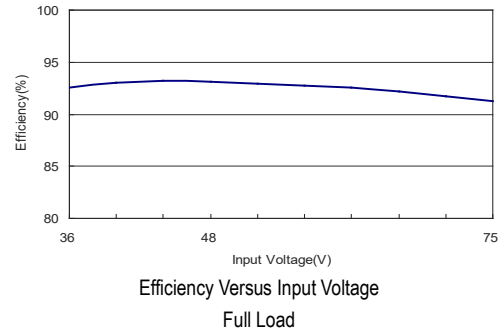
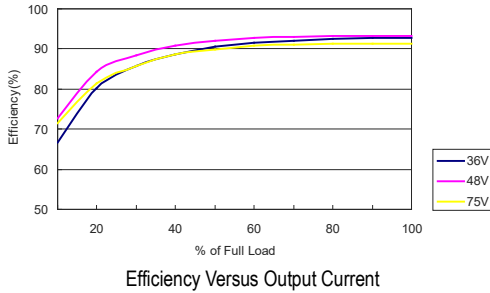

Characteristic Curves

All test conditions are at 25°C The figures are identical for MKW50-48S15

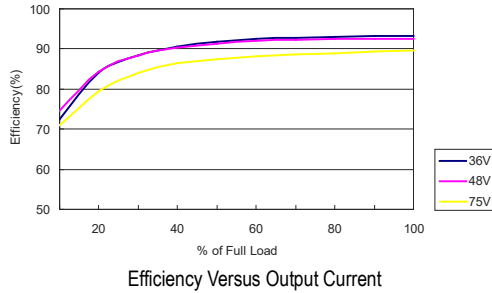

Efficiency Versus Output Current

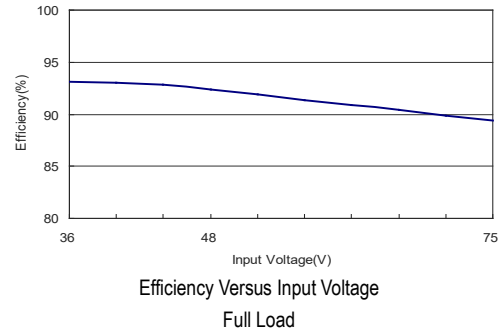

Efficiency Versus Input Voltage Full Load

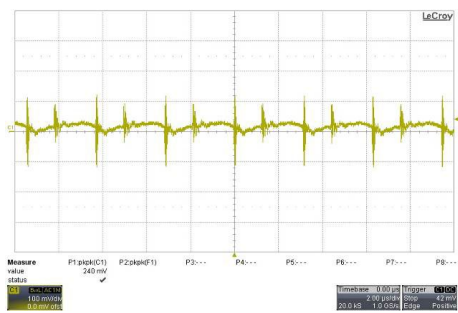

Typical Output Ripple and Noise
 $V_{in}=V_{in\ nom}$; Full Load



Transient Response to Dynamic Load Change
from 100% to 75% of Full Load ; $V_{in}=V_{in\ nom}$

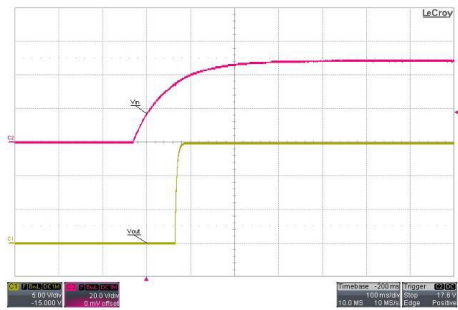

Typical Input Start-Up and Output Rise Characteristic
 $V_{in}=V_{in\ nom}$; Full Load

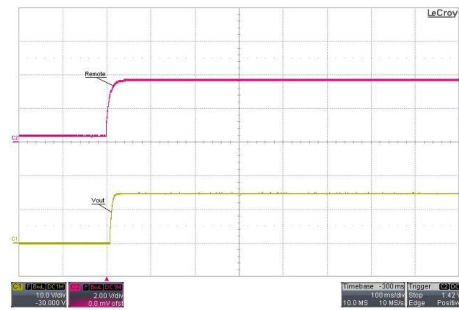

ON/OFF Voltage Start-Up and Output Rise Characteristic
 $V_{in}=V_{in\ nom}$; Full Load

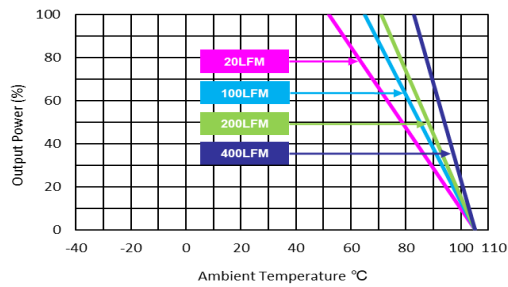

Derating Output Current Versus Ambient Temperature
 $V_{in}=V_{in\ nom}$

Characteristic Curves

All test conditions are at 25°C The figures are identical for MKW50-48S24

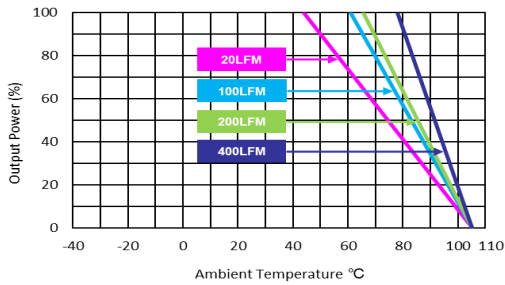
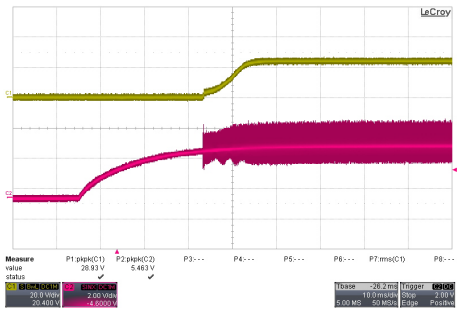
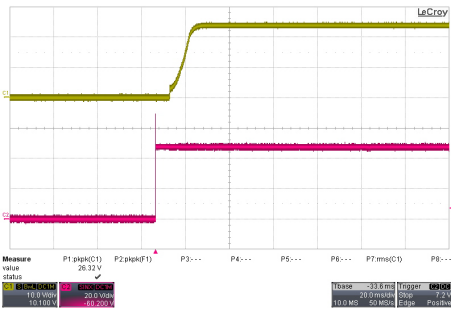
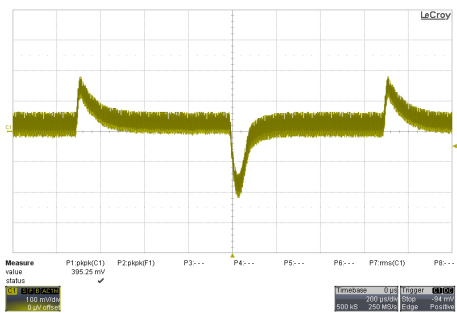
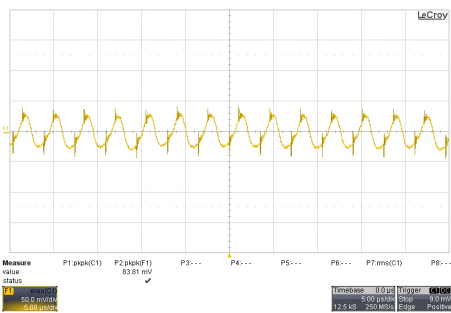
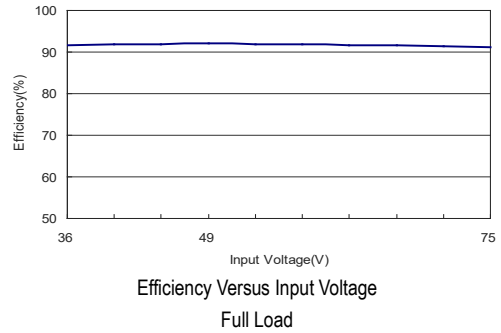
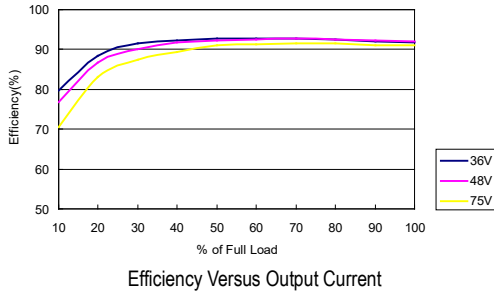

Package Specifications

Mechanical Dimensions

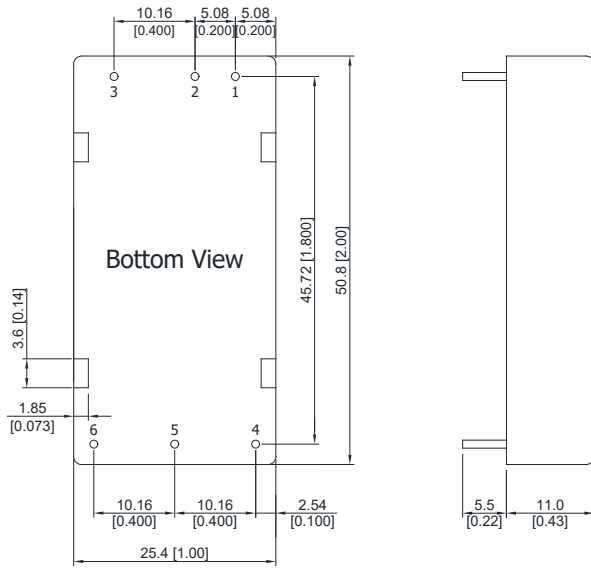

Pin Connections

Pin	Function	Diameter mm (inches)
1	+Vin	∅ 1.0 [0.04]
2	-Vin	∅ 1.0 [0.04]
3	Remote On/Off	∅ 1.0 [0.04]
4	+Vout	∅ 1.0 [0.04]
5	-Vout	∅ 1.0 [0.04]
6	Trim	∅ 1.0 [0.04]

- ▶ All dimensions in mm (inches)
- ▶ Tolerance: X.X±0.25 (X.XX±0.01)
X.XX±0.13 (X.XXX±0.005)
- ▶ Pin diameter tolerance: X.X±0.05 (X.XX±0.002)

Physical Characteristics

Case Size	: 50.8x25.4x11.0mm (2.0x1.0x0.43 inches)
Case Material	: Metal With Non-Conductive Baseplate
Base Material	: FR4 PCB (flammability to UL 94V-0 rated)
Pin Material	: Copper Alloy
Potting Material	: Epoxy (UL94-V0)
Weight	: 30g

Recommended Pad Layout

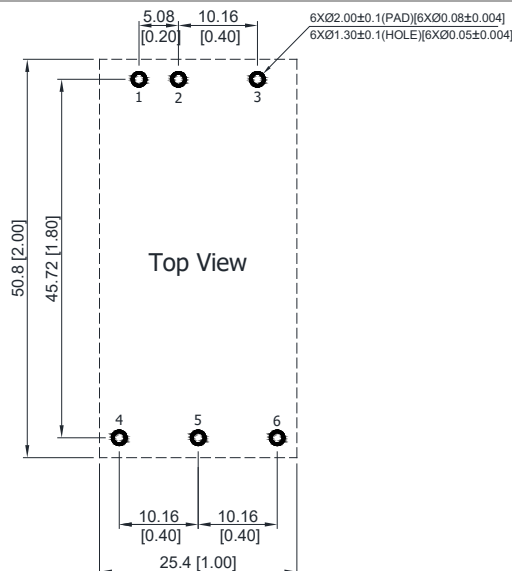

External Output Trimming

Output can be externally trimmed by using the method shown below

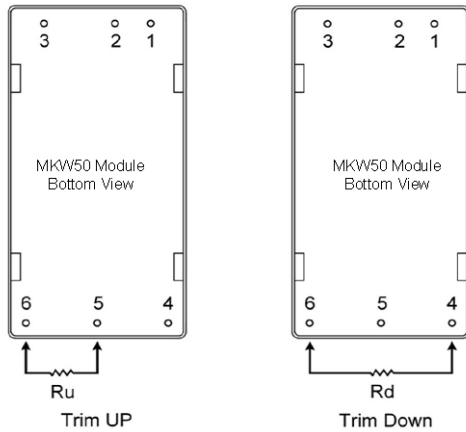

Trim Range (%)	MKW50-XXS033		MKW50-XXS05		MKW50-XXS12		MKW50-XXS15		MKW50-XXS24	
	Trim down (kΩ)	Trim up (kΩ)	Trim down (kΩ)	Trim up (kΩ)	Trim down (kΩ)	Trim up (kΩ)	Trim down (kΩ)	Trim up (kΩ)	Trim down (kΩ)	Trim up (kΩ)
1	72.61	60.84	138.88	106.87	413.55	351.00	530.73	422.77	333.39	---
2	32.55	27.40	62.41	47.76	184.55	157.50	238.61	189.89	148.80	243.70
3	19.20	16.25	36.92	28.06	108.22	93.00	141.24	112.26	87.26	---
4	12.52	10.68	24.18	18.21	70.05	60.75	92.56	73.44	56.50	108.50
5	8.51	7.34	16.53	12.30	47.15	41.40	63.35	50.15	38.04	---
6	5.84	5.11	11.44	8.36	31.88	28.50	43.87	34.63	25.73	63.43
7	3.94	3.51	7.79	5.55	20.98	19.29	29.96	23.54	16.94	---
8	2.51	2.32	5.06	3.44	12.80	12.37	19.53	15.22	10.35	40.90
9	1.39	1.39	2.94	1.79	6.44	7.00	11.41	8.75	5.22	---
10	0.50	0.65	1.24	0.48	1.35	2.70	4.92	3.58	1.12	27.38
12	---	---	---	---	---	---	---	---	---	18.37
14	---	---	---	---	---	---	---	---	---	11.93
16	---	---	---	---	---	---	---	---	---	7.10
18	---	---	---	---	---	---	---	---	---	3.34
20	---	---	---	---	---	---	---	---	---	0.34

Test Setup

Input Reflected-Ripple Current Test Setup

Input reflected-ripple current is measured with an inductor L_{in} (4.7 μ H) and C_{in} (220 μ F, ESR < 1.0 Ω at 100 kHz) to simulate source impedance. Capacitor C_{in} offsets possible battery impedance. Current ripple is measured at the input terminals of the module, measurement bandwidth is 0-500 kHz.

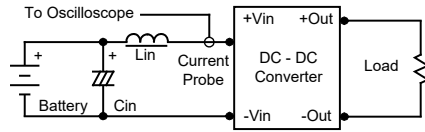

Peak-to-Peak Output Noise Measurement Test

Use a 1 μ F ceramic capacitor and a 10 μ F tantalum capacitor. Scope measurement should be made by using a BNC socket, measurement bandwidth is 0-20 MHz. Position the load between 50 mm and 75 mm from the DC-DC Converter.

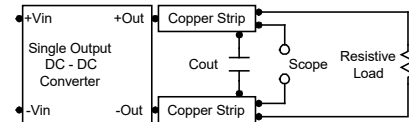

Technical Notes

Remote On/Off

Positive logic remote on/off turns the module on during a logic high voltage on the remote on/off pin, and off during a logic low. To turn the power module on and off, the user must supply a switch to control the voltage between the on/off terminal and the -Vin terminal. The switch can be an open collector or equivalent. A logic low is 0V to 1.2V. A logic high is 3.5V to 12V. The maximum sink current at the on/off terminal (Pin 3) during a logic low is -100 μ A.

Overload Protection

To provide hiccup mode protection in a fault (output overload) condition, the unit is equipped with internal current limiting circuitry and can endure overload for an unlimited duration.

Overvoltage Protection

The output overvoltage clamp consists of control circuitry, which is independent of the primary regulation loop, that monitors the voltage on the output terminals. The control loop of the clamp has a higher voltage set point than the primary loop. This provides a redundant voltage control that reduces the risk of output overvoltage. The OVP level can be found in the output data.

Input Source Impedance

The power module should be connected to a low ac-impedance input source. Highly inductive source impedances can affect the stability of the power module. In applications where power is supplied over long lines and output loading is high, it may be necessary to use a capacitor at the input to ensure startup. Capacitor mounted close to the power module helps ensure stability of the unit, it is recommended to use a good quality low Equivalent Series Resistance (ESR < 1.0 Ω at 100 kHz) capacitor of a 33 μ F for the 12V input devices and a 10 μ F for the 24V and 48V devices.

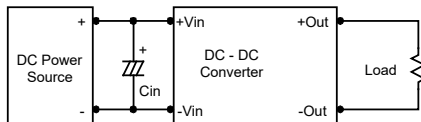

Output Ripple Reduction

A good quality low ESR capacitor placed as close as practicable across the load will give the best ripple and noise performance. To reduce output ripple, it is recommended to use 4.7 μ F capacitors at the output.

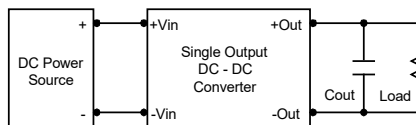

Maximum Capacitive Load

The MKW50 series has limitation of maximum connected capacitance at the output. The power module may be operated in current limiting mode during start-up, affecting the ramp-up and the startup time. The maximum capacitance can be found in the data sheet.

Thermal Considerations

Many conditions affect the thermal performance of the power module, such as orientation, airflow over the module and board spacing. To avoid exceeding the maximum temperature rating of the components inside the power module, the case temperature must be kept below 105°C. The derating curves are determined from measurements obtained in a test setup.

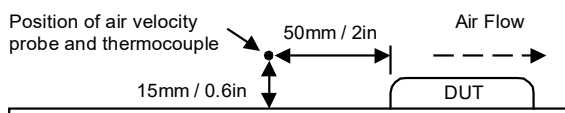

Remote ON/OFF Implementation

With suffix-RC, the positive logic remote ON/OFF control circuit is included. Turns the module ON during logic High on the ON/Off pin and turns OFF during logic Low. The ON/OFF input signal ($V_{on/off}$) that referenced to GND. If not using the remote on/off feature, please open circuit between on/off pin and -Vin pin to turn the module on.

Remote ON/OFF implementation

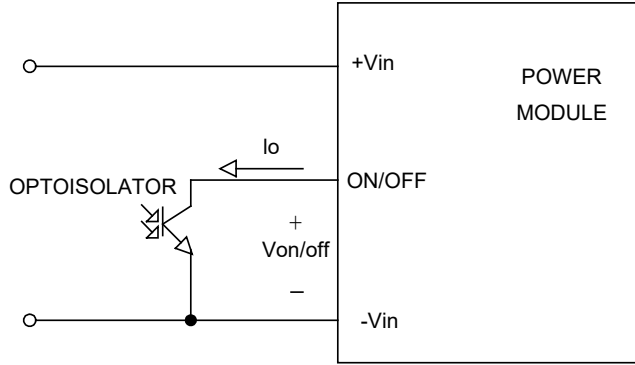

Isolated-Closure Remote ON/OFF

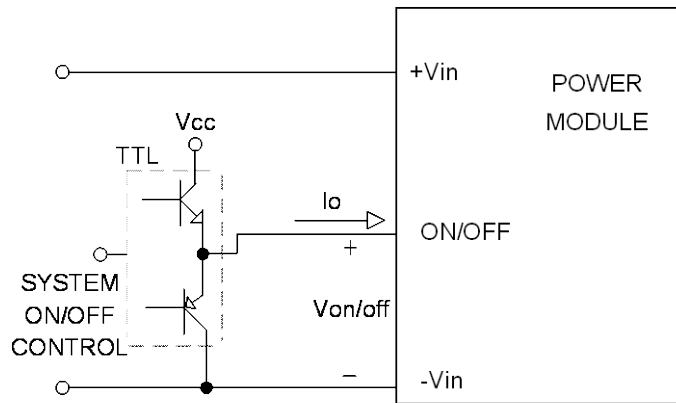

Level Control Using TTL Output

Packaging Information

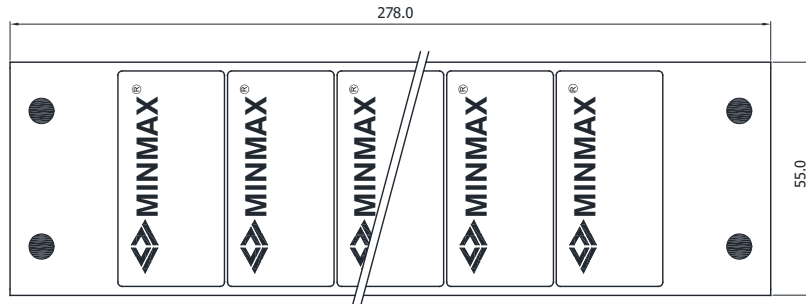
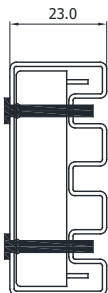

Unit: mm
10 PCS per TUBE

Wave Soldering Considerations

Lead free wave solder profile

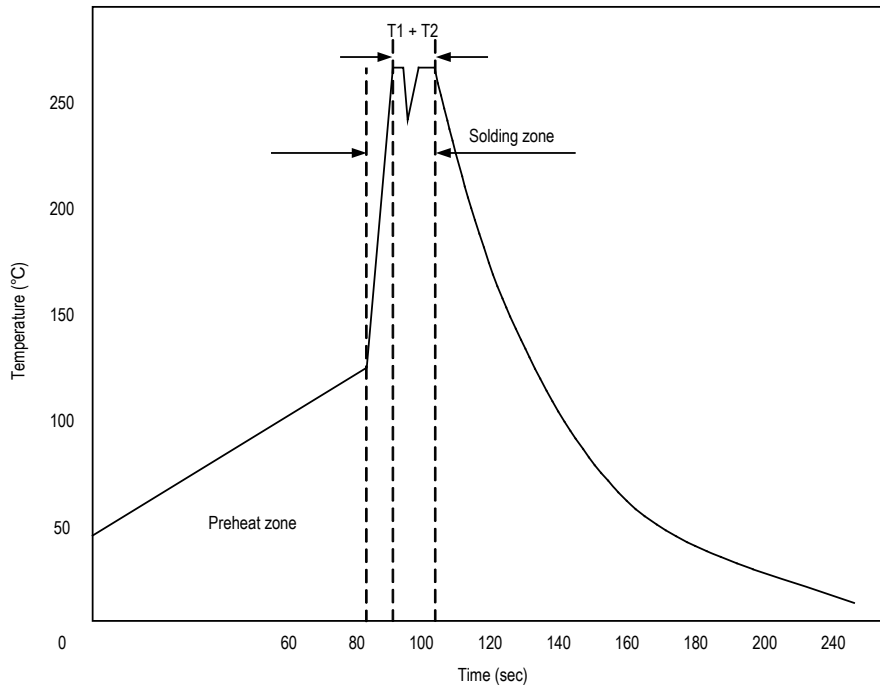

Zone	Reference Parameter
Preheat	Rise temp. speed : 3°C/sec max.
zone	Preheat temp. : 100~130°C
Actual	Peak temp. : 250~260°C
heating	Peak time(T1+T2) : 4~6 sec

Hand Welding Parameter

Reference Solder: Sn-Ag-Cu : Sn-Cu : Sn-Ag

Hand Welding: Soldering iron : Power 60W

Welding Time: 2~4 sec

Temp.: 380~400°C

Part Number Structure

M	K	W	50	-	12	S	033
Package Type 2" X 1"	Wide 2:1 Input Voltage Range	Output Power 50 Watt	Input Voltage Range			Output Quantity S: Single	Output Voltage
			12: 9 ~ 18 VDC			033: 3.3 VDC	
			24: 18 ~ 36 VDC			05: 5 VDC	
			48: 36 ~ 75 VDC			12: 12 VDC	
						15: 15 VDC	
						24: 24 VDC	

MTBF and Reliability

The MTBF of MKW50 series of DC-DC converters has been calculated using

MIL-HDBK 217F NOTICE2, Operating Temperature 25°C, Ground Benign.

Model	MTBF	Unit
MKW50-12S033	316,800	Hours
MKW50-12S05	140,800	
MKW50-12S12	197,900	
MKW50-12S15	202,100	
MKW50-12S24	234,000	
MKW50-24S033	316,700	
MKW50-24S05	234,600	
MKW50-24S12	275,500	
MKW50-24S15	279,200	
MKW50-24S24	257,600	
MKW50-48S033	314,200	
MKW50-48S05	224,700	
MKW50-48S12	265,300	
MKW50-48S15	277,600	
MKW50-48S24	261,900	